



technische import

J+J Productinformatie



J+J AUTOMATION

Feature rich **J+J** multi-voltage smart electric actuator with LED status light and function conversion kits.



J3C-S BSR Failsafe Type



BSR Failsafe plug & play kit pre-installed

How this J3C-S failsafe electric valve actuator works:

Electrically operated valves are driven by a motor and gearbox. On receipt of a continuous voltage signal the motor runs and, via a gearbox in the J+J smart electric actuator, rotates the valve stem. The motor stops at the desired position (usually 0° or 90°) by internal cams striking micro-switches. The smart valve actuator remains in this position, with the voltage still applied continuously, until switched and a continuous voltage reversing signal is applied, which runs the motor in the opposite direction, reversing the rotation until separate set of internal cams strike separate set of micro-switches.

The user friendly BSR failsafe function plug and play conversion kit adds an industrial NiCad rechargeable battery and PCB to the standard power open, power close J3CS actuator. The electric actuator continues to operate power open, power close, and whilst doing so, the battery is constantly trickle charged to keep it fully charged.

When external power is lost, a switch in the BSR PCB draws internal power from the battery to send the J3CS to the desired pre-set 'safe' position, if not already in that position.

Warning on battery use:

Specifying a failsafe electric actuator implies that the actuator is a safety device. As the BSR uses rechargeable batteries, it is imperative that the batteries are maintained at full capacity so that the auxiliary power it creates is available when needed. There are 3 important points to ensure this:

- 1) Charge the battery for at least 27 hours before putting the safety actuator into service.
- 2) Always leave external power connected to ensure the trickle charger (and internal heater) are working.
- 3) Always respect the minimum recharge time for the model you are using to replace the battery charge used during a previous battery movement.

Electrical Connection - Wiring of DIN Plugs

J3CS FAILSAFE ACTUATOR WIRING

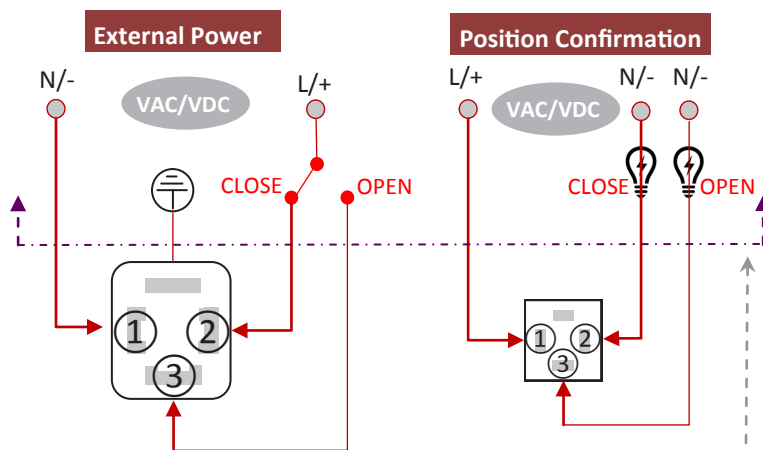

Note: Above line above is customer supplied!

In J+J electric actuators all electrical connections are made externally using the external DIN plugs supplied with the actuator. There is no need to remove the valve actuator's cover to connect electrically. There are no terminals internally to connect to.

Available with actuator function: POWER OPEN - POWER CLOSE **FAILSAFE** MODULATING FAILSAFE MODULATING

Specifications	S20	S35	S55	S85
Max number of movements (90°) with 100% battery charge	5	5	5	5
Recharge time to replace charge used for 1 movement (90°)	8 mins	8 mins	10 mins	10 mins
Battery consumption when driving actuator	6.2W	6.2W	6.2W	6.2W
Initial charge time required before putting into service	28 hours	28 hours	28 hours	28 hours
Nominal battery capacity ±5%	1000mA	1000mA	1000mA	1000mA
Configuration set up method (fail closed or fail open)	Jumper	Jumper	Jumper	Jumper
Battery current draw during battery operation	2.4mA	2.4mA	3.3mA	7.1mA
Battery charge rate	36mA/h	36mA/h	36mA/h	36mA/h
BSR Component weight	0.23Kg	0.23Kg	0.23Kg	0.23Kg

J3CS Multi-colour LED status light:

Actuator operational status	LED Colour
No power being supplied	Off ☼
Power being supplied to actuator	Fully OPEN = Solid ● Fully CLOSED = Solid ●
Actuator moving between open and closed	Open to close = flash ★★ ★★ Close to open = flash ★★ ★★
Actuator in MANUAL mode	Flash ☼ ★★ ☼ ★★ ☼ ★★
Torque limiter activated	If closing when activated = flash ★★ ☼ ★★ ☼ if opening = flash ★★ ☼ ★★ ☼
BSR failsafe system activated (for max 3 mins)	If configured Fail Close = flash ☼☼☼☼ ★★ if Fail Open = flash ☼☼☼☼ ★★
BSR Battery needs charging warning	Flash ★★ ★★ ★★ ★★ ☼ ★★ ★★ ★★ ★★ ☼
Actuator with DPS(2015) positioner	Opening = flash ★★ ★★ Closing = flash ★★ ★★ Stationary = ●

Configuring the BSR:

The bottom black jumper is installed for fail closed function, or removed for fail open function. The position of the jumper on the main blue actuator PCB is marked 'SELDIR'.

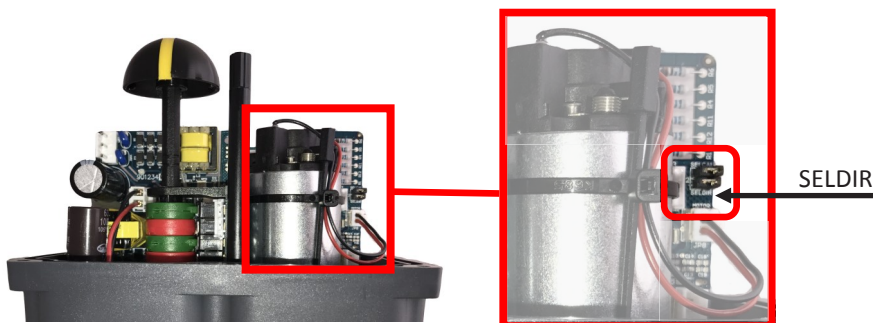



technische import