



technische import

Produkt informatie



HANS SASSERATH & Co. KG

Pressure reducing valve 315

made of gunmetal with outlet pressure indicator



Fig. 1

Field of application

The pressure reducing valve type 315 is predominantly used in the drinking water supply and fulfils the requirements of the European Standard EN 1567. Under consideration of its specifications it also protects industrial and commercial installations against excess supply pressure. The pressure reducing valve type 315 protects water-supplying installations; it

compensates and optimises upstream pressure variations and therefore it effectively prevents damages that can be caused by pressure increase. Furthermore, it economically and ecologically reduces the water consumption. The type 315 meets the highest European acoustic protection requirements.

Design

The pressure reducing valve type 315 is equipped with an outlet pressure indicator (see figure 1) that displays the set pressure. As a result, an additional pressure gauge is not necessary. The spring cap is rotatable by 360°, so that the pressure indicator is always visible. The pressure reducing valve type 315 complies with the European Standard EN 1567 and fulfils the highest acoustic protection requirements up to DN 32. The pressure reducing valve type 315 is

equipped with a spring-relieved single-seat valve and a coaxially positioned strainer (mesh width: 0.25 mm). The operational parts of the system are placed in a cartridge; this complete unit can be exchanged without disassembling the whole valve and without using special tools; the outlet pressure setting remains unchanged. The special cartridge design allows any mounting position.



Pressure reducing valve 315

Materials

The materials used for the SYR pressure reducing valve type 315 comply with the high requirements of European Standards. All synthetic parts getting in contact with water are approved by the German Public Health Office (KTW). The corrosion resistance in particular is guaranteed for all used materials. The body is made of a low-lead dezincification resistant gunmetal alloy. All rubber parts are made of ageing resistant elastomer. The diaphragm is reinforced and the high resistance of the screw cap is due to the glass fibre reinforced synthetic material.

Installation

The connection size depends on the required flow rate capacity. When choosing a pressure reducing valve, it has to be taken into consideration that a pressure drop of 1.3 bar occurs at maximum flow rate. This is the difference between the static and dynamic pressure on the outlet of the pressure reducing valve. When a defined flow rate is required for a determined draw-off point, the setting of the pressure reducer has to be calculated beforehand. A pressure reducing valve works without auxiliary energy with very little adjustment forces. Therefore it reacts sensitively to impurities. A filter installed upstream effectively protects the pressure reducing valve type 315.

Thoroughly rinse the pipe prior to installation. Install the SYR pressure reducing valve type 315 in the pipe under consideration of the flow direction (see arrow on the body) without applying stresses. Afterwards, turn the head part without loosening the captive nut, so that the green outlet pressure indicator becomes visible.

Technical data	Inlet pressure:	max. 16 bar
	Outlet pressure:	1.5 - 6 bar (factory-set to 4 bar)
	Operating temperature:	max. 60 °C
	Reduction ratio:	max. 10 : 1
	Mounting position:	any
	Fluid:	Water, compressed air, fuel oil, neutral non-adhesive fluids, neutral gases
	Acoustic protection approval number:	DN 15-25 P-IX 7635/I, DN 32 P-IX 7729/I
	DVGW-number.:	NW-6330AT2061
	Serial number:	0315...

Maintenance

The pressure has to be set at static pressure. For doing so, loosen the safety screw in the adjustment handle. The requested pressure is set with a flick of the wrist. With the well-contrived combined adjustment-display handle, the pressure reducer not only ensures an optimal pressure but also allows to read the set pressure without an additional pressure gauge. To reduce the outlet pressure, turn the adjustment handle in the direction of the minus symbol (-), to increase it, turn the adjustment handle in the direction of the plus symbol (+). It is recommended to carry out maintenance works on a regular basis to ensure a durable function. The perfected design of the cartridge system allows to disassemble the operational part of the pressure reducing valve without having to disassemble the whole valve and without using special tools.

Pressure reducing valve 315

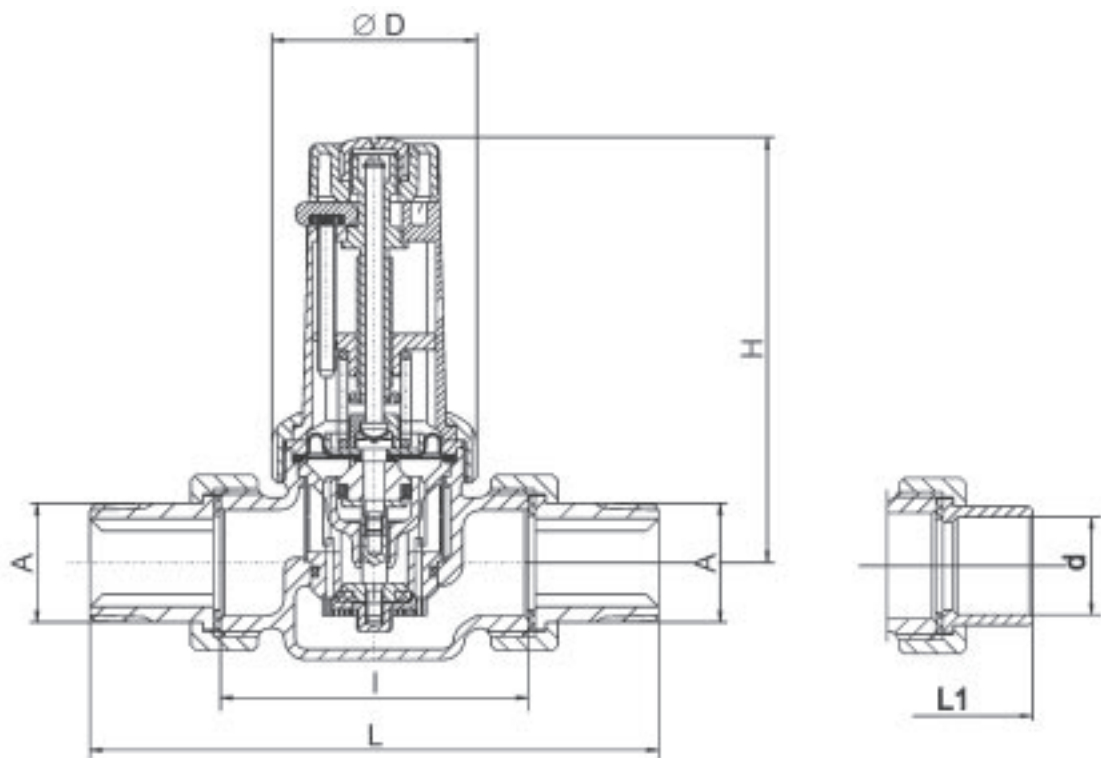

Nominal size		DN 15	DN 20	DN 25	DN 32	DN 40	DN 50
	A	G 1/2	G 3/4	G 1	G 1 1/4	G 1 1/2	G 2
Dimensions in mm	d (mm)	15	22	28	35	42	54
	L (mm)	132	143	161	190	220	255
	L1 (mm)	106	117	135	170	205	240
	I (mm)	75	75	87	105	130	140
	H (mm)	123	123	121	176	176	180
	D (mm)	58	58	58	SW 75	SW 75	SW 75
Flow rate capacity according to EN 1567	Residential buildings	1,8	2,9	4,7	7,2	8,3	13
	Industrial/commercial installations	1,8	3,3	5,4	8,6	13,7	21,2

Accessory

Manometer: type 11

Pressure reducing valve 315

Components/order numbers

- ①
Pressure reducer cartridge
with outlet pressure
indicator
DN 15+20 0315.20.904
DN 25 0315.25.904
DN 32-50 0315.32.902
- ②
Threaded union and seal
DN 15 0812.15.900
DN 20 0812.20.900
DN 25 0812.25.900
DN 32 0812.32.900
DN 40 0812.40.900
DN 50 0812.50.900
- ③
Manometer plug
0828.08.000
- ④
Body

