



technische import

Produkt informatie



HANS SASSERATH & Co. KG

Water level limiter 932

Protection against insufficient water level in boilers



Field of application

The water level limiter type 932 protects boilers in heating installations against dry-heating resulting from an insufficient water level. The installation of such a device is highly recommended for safety reasons.

The water level limiter type 932 can also be used for any device, which operates with water level dependent electric switches and requires a test possibility without lowering the water level.

Design

The water level limiter type 932 is designed with magnetic transmission of the float movement to a microswitch; it allows testing without lowering the water level. The electric switch unit is rotatable by 360° and can be exchanged without draining the installation. The water level limiter type 932

isolates the system after cutting the burner off. When the malfunction is eliminated, re-connect the system by means of the unlock key on the water level limiter. Another type with a compacter construction form is available as special model 932.5.



Water level limiter 932

Materials

The nipple, the test sensor, the magnetic glide sleeve and the internal parts are made of a high quality low-lead brass alloy. The float is made of a heat and pressure resistant special glass and the switch unit body of synthetic material. All brass and copper parts in contact with water are

nickel-plated. The sealing elements are made of heat and ageing resistant elastomeric synthetic material. The electric connection is made with a hardwired cable H 05 VV-F 4G 0.75 mm², length 2.5 m.

Installation

Screw the water level limiter type 932 in the pre-installed connection piece (DN 50) on the boiler. When installing, imperatively ensure that the float is not damaged. The electric connection has to be made by an electrician in compliance with the prescriptions of the local power supply company under consideration of the circuit

diagram and the cable designation. After the installation, fill and vent the system. Afterwards, vent the water level limiter separately: loosen the gland packing on the test sensor until water comes out; then, re-tighten. To start up the installation, pull the test sensor upwards to the stop; then, press the unlock key.

Technical data

Operating overpressure:	max. 10 bar
Operating temperature:	max. 120 °C
Type of protection:	IP 65
Microswitch:	on-off switch, single pole
Mounting position:	Main axis vertical
Capacity:	10 (4) A / 250 Volt
Component approval:	TÜV - HWB - 01-206
Serial number:	0932...

Maintenance

The device requires no regular maintenance. However, it should be unlocked manually once per year in order to test functionality. All components can be

exchanged separately. The switch unit can be exchanged without draining the installation.

Water level limiter 932

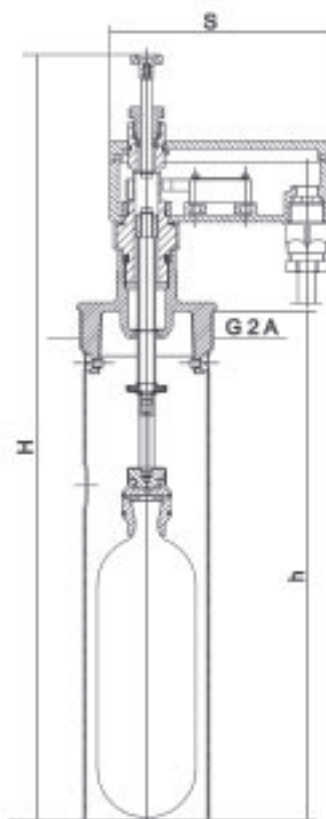

932.1

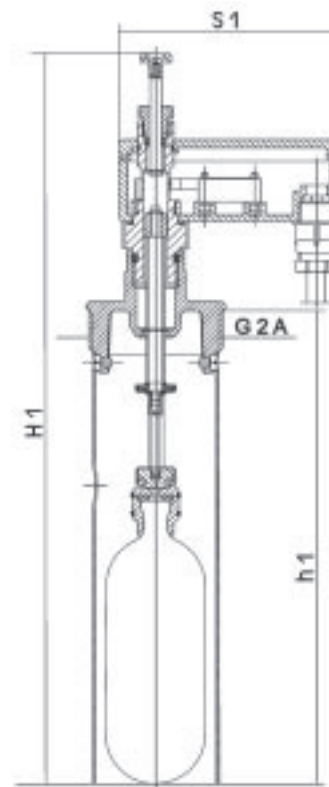

932.5

Nominal size		DN 50
Dimensions	A	G 2
	H (mm)	343
	h (mm)	229
	S (mm)	64 x 98
	H 1 (mm)	247
	h 1 (mm)	150
	S 1 (mm)	64 x 98

Models: Type 932.1 standard construction form
Typ 932.5 compact construction form

Water level limiter 932

Components / Order numbers

- ①
Test sensor
0933.20.911
0932.50.904 (932.5)
- ②
Microswitch
0933.20.912
- ③
Switch unit
0932.50.901
0932.50.905 (932.5)
- ④
Complete float device
0932.50.901
0932.50.903 (932.5)
- ⑤
Glass float
0933.20.906
0932.50.906 (932.5)
- ⑥
**Immersion sleeve with
screws**
0932.50.906

