



technische import

Produkt informatie

COSTER

COSTER T.E.

THREE-PORT BALL ZONE VALVES

PN 10 ; 5...120 °C

HMM 3.. Eng. 



- Body in brass
- Ball in hard chromed brass
- Male threaded connections with unions
- Teflon and Viton seals



1. APPLICATION



HMM3 valves are designed to control water flow in heating and cooling systems. They are particularly suitable for zone plants, fan-coil plants and for mounting on modular manifolds.

They can be operated by hand or by rotary actuators model CDK and CDR.

Permitted fluids :

- hot water max. 120 °C,
- chilled water min. 5 °C,
- water with max. 50 % glycol.

2. MODELS

Code	DN body mm	Valve unions inches	Pipe unions inches	Kvs ⁽¹⁾ m ³ /h	Suitable actuators CDK ... - CDR ...
3 port		male	male	 	kPa ⁽²⁾ (bar) sec. ⁽³⁾
HMM 320	20	1"	3/4"	11	600 (6) 60
HMM 325	25	1"1/4"	1"	25.7	600 (6) 60

(1) Kvs = flow coefficient : flow in m³/h with valve open and pressure drop of 100 kPa.

(2) kPa = maximum differential pressure Δp permitted by actuator: 100 kPa = 10 mWG = 1 bar

(3) sec. = time necessary for actuator to make complete valve run.

3. TYPICAL APPLICATION DIAGRAM

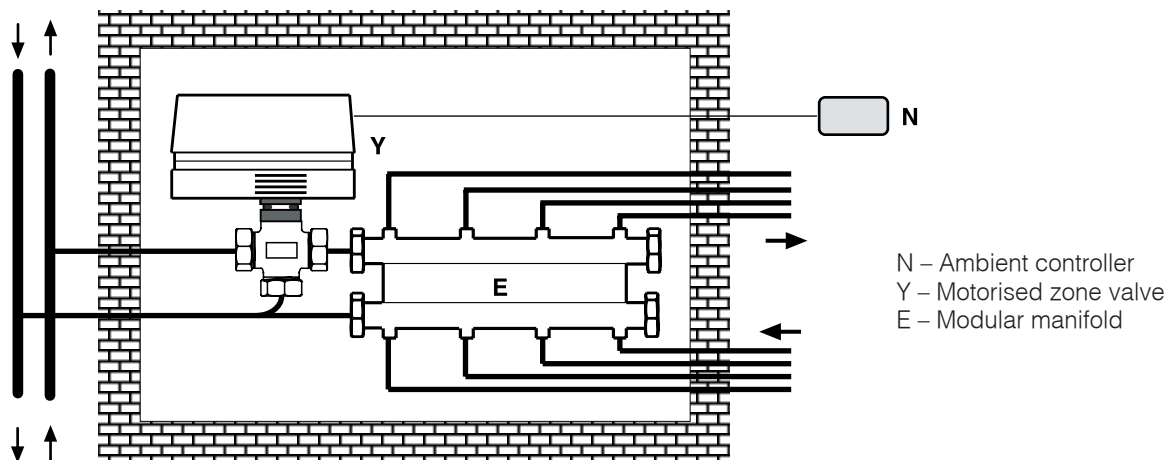

4. TECHNICAL DATA

Valve body	OT58 brass	Connections	male threaded with unions
Spindle	stainless steel	Nominal pressure	1000 kPa (10 bar)
Ball	hard chromed OT58 brass	Fluid temperature	5...120 °C
Seals :		Run	90°
• - ball and nut seal	PTFE (teflon)		
- spindle	viton O-Ring		

5. OVERALL DIMENSIONS

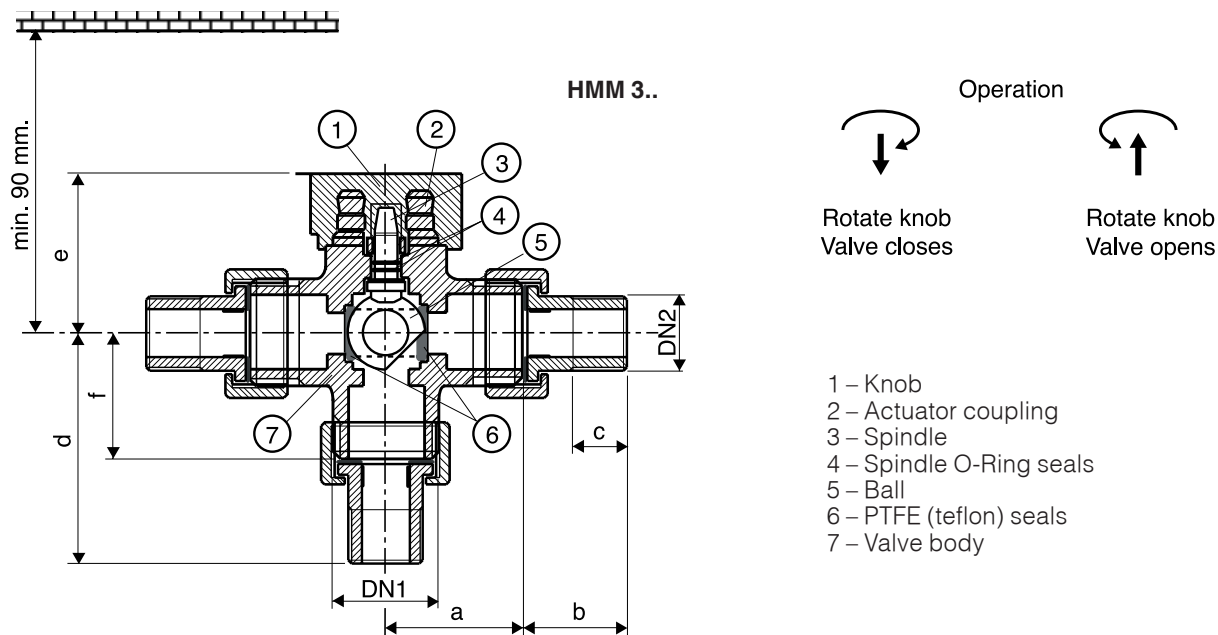

Model	DN 1 inches	DN 2 inches	a mm	b mm	c mm	d mm	e mm	f mm
HMM 320	1"	3/4"	25.5	30.5	12	60.5	41	30
HMM 325	1"1/4	1"	31.5	35.5	13	72	47	36.5

6. CONSTRUCTION

The valve body (5.7) is made in OT58 brass, the spindle (5.3) is in stainless steel and the ball (5.5) is in hard chromed OT58 brass. The ball is enclosed by two seals (5.6) in PTFE (teflon) which ensure the total absence of let-by, while the spindle seal is ensured by two viton O-Rings (5.4). At the head of the valve is a knob (5.1) for the manual control of the ball.

7. MOUNTING

7.1 Mounting of the valve

Before mounting the valve make sure that there isn't any extraneous matter in the pipework (remains of welding or threading). The pipework must not be subject to vibrations and must be perfectly aligned with the valve unions in order to avoid dangerous strains. The valve can be mounted in any position except with the spindle facing downwards.

Leave enough space on the spindle side for the mounting of actuator (see section 5).

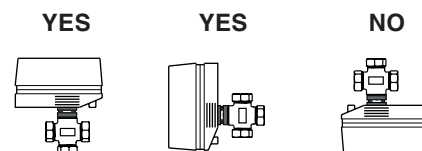

7.2 Installing the actuator on the valve

CDK actuator: set the valve in the closed position manually. Pull out the hand grip and then insert and push down the CDK actuator (factory setting: "Closed").

CDR actuator: set the valve in closed position manually. Pull out the hand grip and then, using a suitable tool, set the valve in the open position. Then insert and push down the CDR actuator (factory setting: "Open").

8. OPERATION

The valve operates with a 90° rotary movement. The throughport is full bore with high flow coefficient, the by pass has narrow cross section with reduced flow coefficient. The valve can be operated by hand, using the hand grip, or by the CDK or CDR actuator. A mark on the valve spindle, also visible when the actuator is installed, indicates the position of the valve.