



technische import

Produkt informatie



ENOLGAS

Three Way ball valve, "T", TYPE R2070

Características

1. Válvula esfera tres vías paso reducido.
2. Configuración de Esfera en "T".
3. Extremos roscados según ISO 7-1 (EN 10226-1).
4. Construcción en acero inox. 1.4408 (CF8M).
5. Cuatro Asientos PTFE + 15 % Fibra de Vidrio.
(otros materiales consultar).
6. Juntas del eje PTFE.
7. Tórica en el eje de FKM (Viton).
8. Dispositivo Anti-estático (Esfera-eje-cuerpo).
9. Sistema de bloqueo.
10. Montaje actuador directo s/ ISO 5211.
11. Eje inexpulsable.
12. Presión de trabajo máxima 63 bar.
13. Temperatura de trabajo $-25\text{ }^{\circ}\text{C} + 180\text{ }^{\circ}\text{C}$.

Features

1. 3 Way reduced port ball valve.
2. "T" Ball configuration.
3. Threaded ends according to ISO 7-1 (EN 10226-1).
4. Made of stainless steel 1.4408 (CF8M).
5. Four Ball seats PTFE + 15 % G.F.
(please ask for other materials).
6. Stem gasket PTFE.
7. FKM (Viton) stem o'ring.
8. Anti-static device (Ball - Stem - Body).
9. Locking system.
10. Direct mounting actuator according to ISO 5211.
11. Blow-out proof stem.
12. Max. Working pressure 63 bar.
13. Working Temperature $-25\text{ }^{\circ}\text{C} + 180\text{ }^{\circ}\text{C}$.

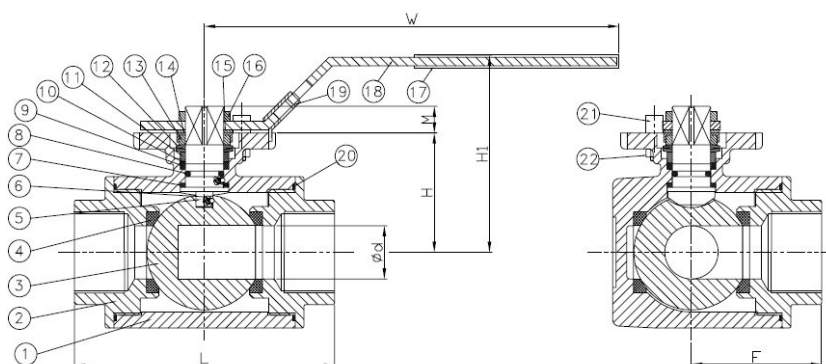

Nº	Denominación / Name	Material	Acabado Superficial / Surface Treatment	Kit Ref.
1	Cuerpo / Body	Acero Inox. / Stainless Steel 1.4408	Granallado + Decapado / Shot blasting + Pickling	-----
2	Tapa / Cap	Acero Inox. / Stainless Steel 1.4408	Granallado + Decapado / Shot blasting + Pickling	-----
3*	Bola / Ball	Acero Inox. / Stainless Steel 1.4408	-----	2841
4*	Asiento / Ball Seat	Teflón + 15% FV / PTFE + 15% FG	-----	2819
5	Eje / Stem	Acero Inox AISI 316 / SS 316	-----	-----
6	Dispositivo Anti-estático / Anti-Static device	Acero Inox AISI 316 / SS 316	-----	-----
7*	Anillo Fricción / Thrust Washer	PTFE	-----	2819
8*	Tórica / O' ring	FKM (Viton)	-----	2819
9*	Empaquetadura / Stem packing	PTFE	-----	2819
10	Guarnición / Bushing	Inox. + PTFE / S.S. + PTFE	-----	-----
11	Anillo Prensa / Gland	Acero Inox AISI 304 / SS 304	-----	-----
12	Arandela Resorte / Spring Washer	Acero Inox AISI 301 / SS 301	-----	-----
13	Tuerca / Nut	ASTM A194-8	-----	-----

Nº	Denominación / Name	Material	Acabado Superficial / Surface Treatment	Kit Ref.
14	Antigiro / Stopper	Acero Inox AISI 304 / SS 304	-----	-----
15	Arandela / Washer	Acero Inox AISI 304 / SS 304	-----	-----
16	Tuerca Maneta / Handle Nut	Acero Inox AISI 304 / SS 304	-----	-----
17	Funda / Handle Sleeve	Vynil	-----	-----
18	Maneta / Handle	Acero Inox AISI 304 / SS 304	-----	-----
19	Bloqueo maneta / Lock device	Acero Inox AISI 304 / SS 304	-----	-----
20*	Junta / Gasket	PTFE	-----	2819
21	Tornillo Tope / Stop Bolt	Acero Inox AISI 304 / SS 304	-----	-----
22	Tuerca / Nut	ASTM A194-8	-----	-----

* Piezas de recambio disponibles / Available spare parts

DIMENSIONES GENERALES / GENERAL DIMENSIONS

	Medida / Size	PN	d	Dimensiones / Dimensions (mm)								Peso / Weight (Kg)
				L	H	H1	W	M	F	C x C	ISO 5211	
	1/4"	63	9.5	75	37	66	130	7	37	9 x 9	F03 / F04	0,700
	3/8"	63	11	75	37	66	130	7	37	9 x 9	F03 / F04	0,670
	1/2"	63	12	75	37	66	130	7	37	9 x 9	F03 / F04	0,630
	3/4"	63	15	85	41	72	161	7	42	11 x 11	F04 / F05	0,950
	1"	63	20	100	47	77	161	7	50	11 x 11	F04 / F05	1,400
	1 1/4"	63	25	122	56	92	203	7	61	14 x 14	F05 / F07	2,900
	1 1/2"	63	32	131	60	96	203	12	65	14 x 14	F05 / F07	3,600
	2"	63	40	158	71	107	203	12	79	14 x 14	F05 / F07	6,250
	2 1/2"	63	49	178	95	135	254	14	89	17 x 17	F07 / F10	8,720

Dispositivo Antiestático / Anti-static Device

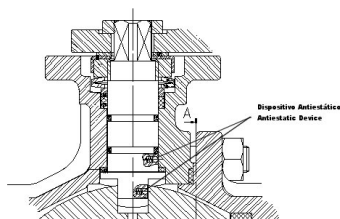

Este dispositivo garantiza la continuidad eléctrica entre esfera - eje - cuerpo, esto es de especial necesidad en fluidos inflamables. / This device ensures the electric continuity between Ball - Stem - Body, this is of special need in flammable fluids.

Detalle de la zona de Eje / *Stem detail*

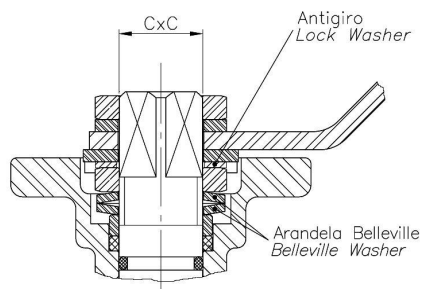

Antigiro / *Lock Washer*: Previene el desajuste de la tuerca del eje en elevados ciclos de maniobra / *Prevents unthreading of stem nut in high cycle automation applications.*

Arandela Belleville / *Belleville Washer*: Las arandelas belleville proporcionan una carga constante sobre el prensa asegurando un cierre firme en variaciones de condiciones de trabajo. / *Standard belleville washers provide constant "live load" on the stem seals, assuring a tight seal even varying service parameters.*

Configuraciones de flujo para válvula de tres vías "T – PORT" "giro 90°" / *Flow Patterns for "T-PORT" "3 way valves 90° turn.*

Dirección del fluido / *Flow pattern (Art.2041)*

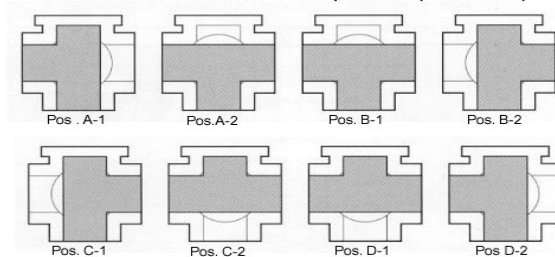

CURVA PRESION TEMPERATURA / *PRESSURE TEMPERATURE RATING*

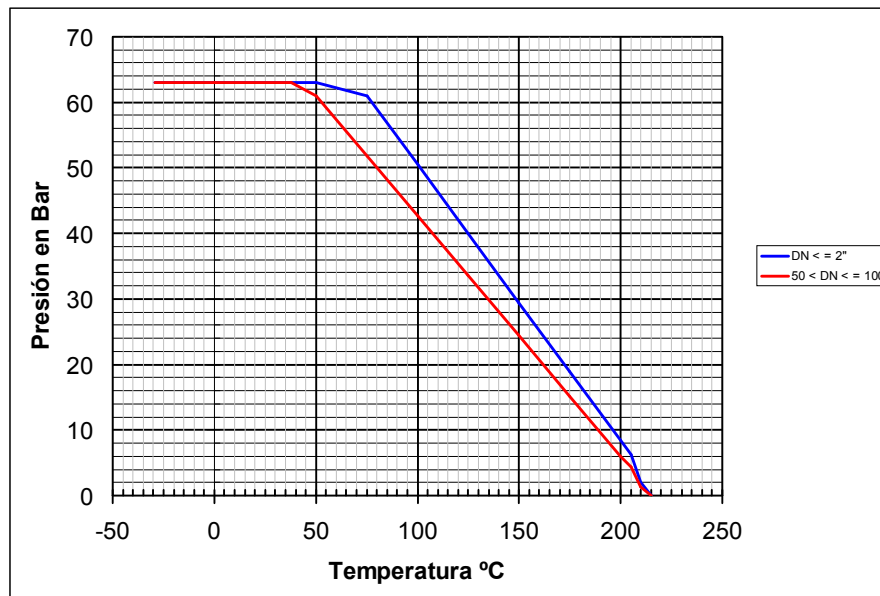

VALORES DE Kv / *Kv VALUES*

K_v (m^3/h) = Es la cantidad de metros cúbicos por hora que pasará a través de la válvula generando una pérdida de carga de 1 bar.

K_v (m^3/h) = *Flow rate of water in cubic meter per hour that will generate a pressure drop of 1 bar across the valve.*

Medida / <i>Size</i>	1/4"	3/8"	1/2"	3/4"	1"	1 1/4"	1 1/2"	2"	2 1/2"
m^3/h	11	11	13	15	31	39	62	103	205



technische import