



bafa
technische import

Syr Handleiding



HANS SASSERATH & Co. KG

bafa.nl

Please note :

The water level limiter, type 932.1 features a built-in interlock and can be directly connected into the control circuit. Interlock deactivation takes place at the water level limiter. The water level limiter, type 932.2 does not have an interlock. This interlock must be provided via the following electrical circuit.

The enclosed instructions for use must be placed in the heating room in good view of the user, and the contained information must be observed during operation.

If the water level limiter should fail to function properly, even after following the directions in this instructions and checking the electrical connection, the complete switch unit can be replaced with the system filled, provided the float is not damaged.

For this, slowly loosen and unscrew the nickel-plated hexagon (fig.3, [1]), a slight amount of water may be discharged. The system is sealed off from the outside by means of an incorporated sealing element, which opens and renders the system operational when the new switching unit is screwed in.

Fig. 3

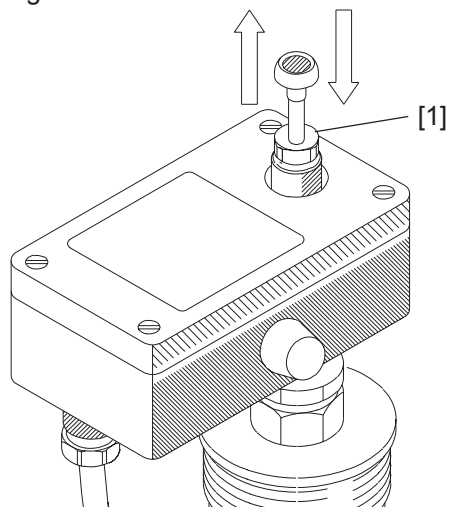

Spare parts

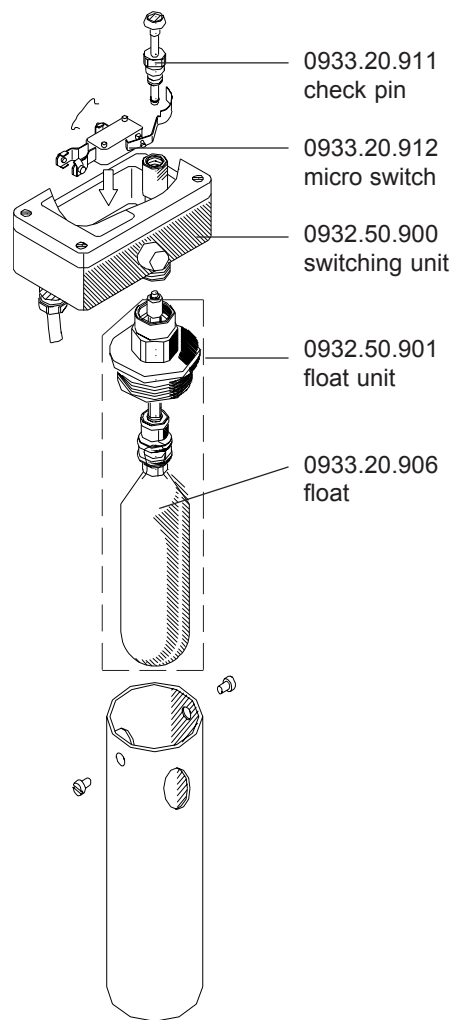

SYR® **ARMATUREN**

Made in Germany

Instructions for use

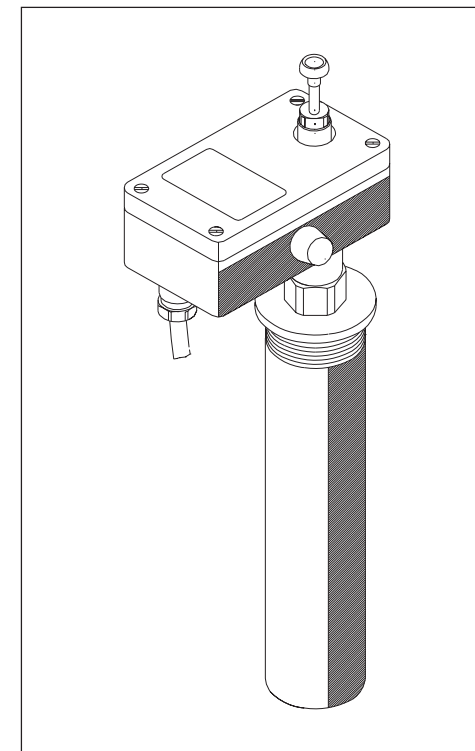

Water level limiter

932.1
932.2

Field of application

Specified as a safety device, the water level limiter serves to protect boilers in closed circuit heating systems against water deficiency. Further it may be used, wherever a control dependent on the water level is useful.

Design

The water level limiter is a glandless device with magnetic transmission of float movement to a microswitch. Type 932.1 with built-in interlock. Type 932.2 without interlock.

Working pressure :	max. 10 bar
Operating temperature :	max. 120°C
Connecting cable :	H 05 VV-F 4G 0,75mm ² , length 4,1m
Cable coding :	yellow/green - protective conductor black - phase blue - burner brown - malfunction indicator
Microswitch :	Changeover contact; 1pole switching capacity 10 (3) A / 250V AC
Degree of protection :	IP 65
Component test-no.:	TÜV - HWB - 01-206
VDE-Reg.-Nr.:	10074

Installation and maintenance should be done by especially trained persons only.

The water level limiter must be connected with the cable fitted at the works in compliance with the applicable specifications and regulations of the local energy supply companies. This work must be undertaken by a qualified electrician according to fig.1.

Installation

The water level limiter 932 must be installed in a vertical position to a special 2" socket on top of the heating vessel.

For electrical connection see fig. 1.

Electric circuit diagramm :

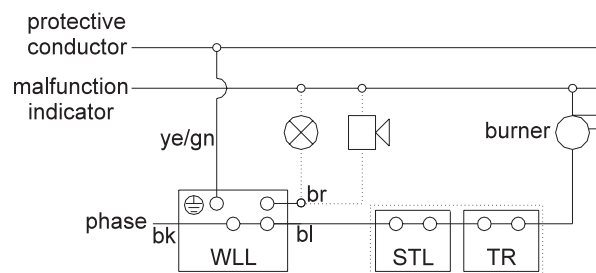

WLL = water level limiter
STL = safety temperature limiter
TR = temperature regulator

Fig. 1

Operation

After the installation of the water level limiter, the heating system must be refilled and unvented.

After unventing the heating system, the water level limiter must be unvented separately.

To do this, loosen gland package (use wrench 15mm) until water pours out (see fig.2). As soon as water starts to discharge retighten the gland to extent that the check pin can still be operated smoothly.

Fig. 2

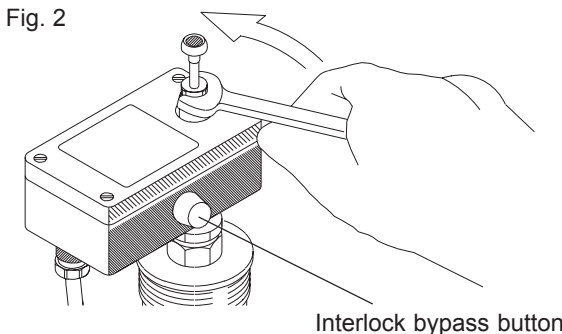

For operation, pull check pin upwards and push interlock bypass button.

Maintenance

At the beginning of the heating period, the water level limiter should be checked at regular intervals, or at least once a year to ensure proper function.

For this, push the check pin downwards. The float is lowered and the system is disconnected. When the check pin is pulled out upwards to its initial position the system must remain disconnected. Reconnection takes place by actuating the interlock bypass button.

Possible operating faults :

Inclusions of air or gas in the area of the float can result in disconnection of the system. The system can be rendered ready for operation by actuating the interlock bypass button. If this fault occurs frequently, the cause of the fault must be located. Special attention should be directed to slight leakages or a possibly defective pressure expansion tank.

IMPORTANT :

The pressure gauge reading is not a direct indication of sufficient filling in a closed circuit heating installation.



technische import