



technische import

Produkt informatie

COSTER

COSTER T.E.

**REVERSIBLE ROTARY ACTUATOR
FOR HGM - HMM - VDM VALVES
POWER SUPPLY 12 V~**

CDK 062 - 032 Eng.



- EXTRACTABLE TERMINAL BLOCK
- RAPID MOUNTING ON VALVE
- 3-wire electric control (common, opens, closes)
- Auxiliary SPDT miniature switch
- IP 53 protection
- Power supply: 12 V~

1. APPLICATION

CDK 062 - 032 actuators is designed to operate COSTER valves: HGM - HMM (ball) and VDM (with ceramic disk). The actuator is mounted directly on the valve so that no linkage kit is required.

2. OPERATION

CDK 062 - 032 actuators incorporate a reversible synchronous electric motor with three-wire electric control (common, opens, closes). It can be controlled by an On-Off or modulating device (thermostat, switch, modulating controller) provided with an SPDT output switch.

The electric motor transmits the rotary movement to the mechanical reducing gear which governs the rotation speed of the output shaft and, accordingly, the actuator run time.

The actuator run is 90° and is limited by two miniature switches operated by an end-of-run cam.

It is fitted with a voltage-free SPDT auxiliary miniature switch (**switching takes place at approximately the half-run of the actuator**).

3. MODELS

| Model | Power supply V~ (VA) | Run time seconds | Nominal torque kg/cm (Nm) | Starting torque kg/cm (Nm) | Valves (up to DN) HGM-HMM-VDM |
|----------------|-------------------------|---------------------|------------------------------|-------------------------------|----------------------------------|
| CDK 062 | 12 (4) | 60 | 15 (1.5) | 30 (3.0) | 1" |
| CDK 032 | 12 (4) | 30 | 10 (1.0) | 20 (2.0) | 3/4" |

4. OVERALL DIMENSIONS

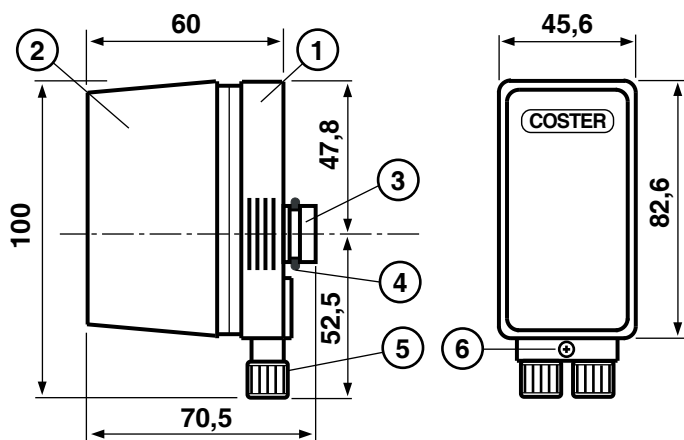

- 1 – Base
- 2 – Protective cover
- 3 – Coupling for valve
- 4 – Actuator/ valve locking spring
- 5 – Unions for passage cables
- 6 – Securing screws for terminal block protective cover

5. TECHNICAL DATA

| | |
|------------------------------|----------------------|
| Power supply | 12 V~ ± 10% |
| Frequency | 50...60 Hz |
| Consumption | 4 VA |
| Protection | IP 53 |
| Rotation angle | fixed at a 90° |
| Run time | |
| CDK 062 | 60 seconds |
| CDK 032 | 30 seconds |
| Torque CDK 062: | |
| Nominal | 15 kg/cm (1.5 Nm) |
| Starting | 30 kg/cm (3.0 Nm) |
| Torque CDK 032: | |
| Nominal | 10 kg/cm (1.0 Nm) |
| Starting | 20 kg/cm (2.0 Nm) |
| For control valves : | |
| HGM - HMM | up to DN 1" |
| VDM | up to DN 1" |
| Auxiliary miniature switch : | |
| maximum switching voltage | 250 V~ |
| maximum switching current | 5 (1) A |
| Materials : | |
| Base | ABS with glass fibre |
| Cover | ABS |
| Valve fluid temperature | 5...95 °C |
| Ambient temperature: | |
| Operating | 0...45 °C |
| Storage | - 20...+ 60 °C |
| Weight | 0.210 kg |

6. CONSTRUCTION

The actuator base is made of ABS reinforced with glass fibre; the cover is in ABS. Two openings, furnished with cable-strain relief bushing grips, permit the passage of the electric cables. The coupling device, at the rear of the base, permits rapid mounting of the actuator on the valve..

7. ELECTRICAL CONNECTIONS

- To ensure a good protection and seal, the outside diameter of the cables must be between 6.25 and 7 millimetres.
- Cable maximum cross section FROR 2x1mm² or FROR 3x0.75mm². Do not use FROR 3x1 mm².
- Loosen the securing screw (3.6) and the two unions for the passage of the cables (3.5), and remove the protective cover from the terminal block.
- Slip the unions on to the cables.
- **To facilitate making the connections the terminal block can be removed.**
- Make the electrical connections following carefully the diagram in 10. WIRING DIAGRAM.
- Having made the connections, insert the terminal block (if it has been removed), replace the protective cover, tighten up the unions and then secure the whole with the securing screw.

The union corresponding to the auxiliary switch connection terminals is closed so as to ensure the necessary protection for the actuator in the event that the auxiliary itself is not used. To connect it, it is necessary to open the union passage by breaking the internal protective membrane.

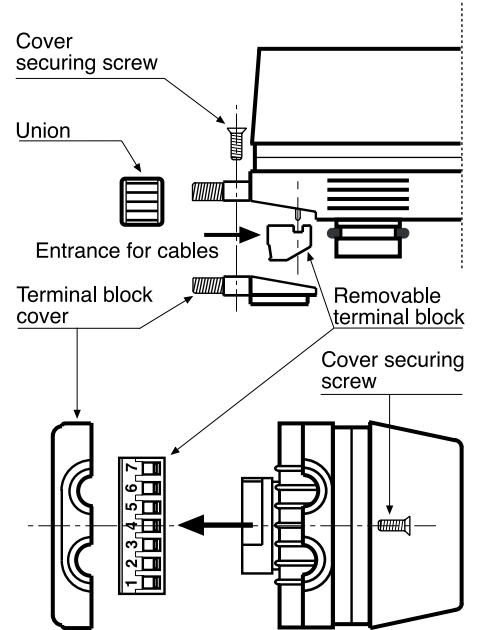

8. MOUNTING THE ACTUATOR ON THE VALVE

- Check the position of the milling on the actuator shaft..
- If necessary, rotate the valve spindle to make it coincide with the milling on the actuator shaft
- Position the actuator on the valve by inserting the two pivot pins on the latter into the two corresponding holes in the base; then press hard on the head of the actuator until you feel it snap into position on the valve.
- Power the actuator and have it make a couple of complete runs to ensure it works correctly.

9. INSTALLATION IN PLANT

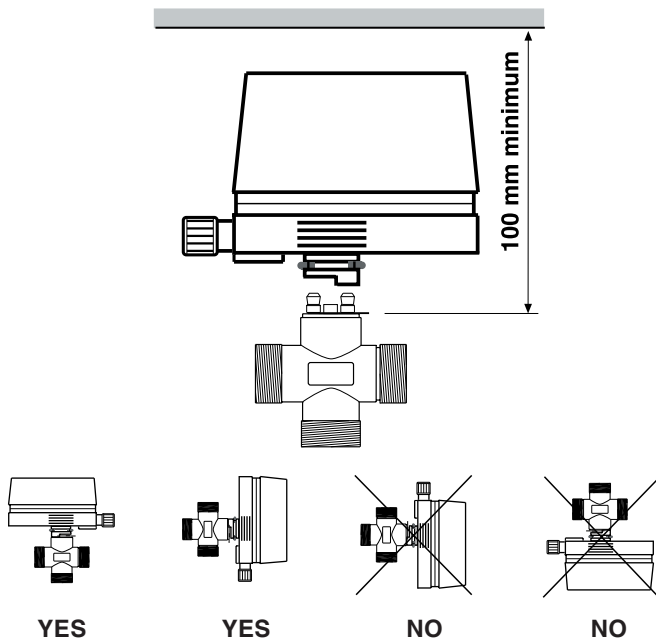

10. WIRING DIAGRAM

