



technische import

J+J Productinformatie



J+J AUTOMATION



FIP PLASTIC VALVES



VKD DN 10÷50

FIP has developed a VKD DUAL BLOCK® ball valve to introduce a high reference standard in thermoplastic valve design. VKD is a True Union ball valve that meets the most stringent needs required by industrial applications.



DUAL BLOCK® 2-WAY BALL VALVE

- Connection system for solvent weld, threaded and flanged joints
- Patented **SEAT STOP®** ball carrier system that lets you micro-adjust ball seats and minimise the axial force effect
- Easy radial dismounting allowing quick replacement of O-rings and ball seats without any need for tools
- **PN16 True Union valve body** made for rigid PVC-U injection moulding equipped with built-in bores for actuation. ISO 9393 compliant test requirements
- Option of dismounting downstream pipes with the valve in the closed position
- Floating **full bore ball** with high surface finish
- **Integrated bracket** for valve anchoring
- Ball seat carriers can be adjusted using the **Easytorque adjustment kit**
- Possibility to have handle with integrated LSQT limit micro switch, even as a retrofit in existing installations

Technical specifications

Construction	2-way True Union ball valve with locked carrier and union nuts.
Nominal pressure	DN 10 ÷ 50
Temperature range	PN 16 with water at 20 °C
Temperature range	0 °C ÷ 60 °C
Coupling standards	<p>Solvent welding: EN ISO 1452, EN ISO 15493, BS 4346-1, DIN 8063, NF T54-028, ASTM D 2467, JIS K 6743. Piping coupling as EN ISO 1452, EN ISO 15493, DIN 8062, NF T54-016, ASTM D 1785, JIS K 6741.</p> <p>Thread: ISO 228-1, DIN 2999, ASTM D 2464, JIS B 0203.</p> <p>Flanging system: ISO 7005-1, EN ISO 1452, EN ISO 15493, EN 558-1, DIN 2501, ANSI B.16.5 cl. 150, JIS B 2220.</p>
Reference standards	<p>Construction criteria: EN ISO 16135, EN ISO 1452, EN ISO 15493</p> <p>Test methods and requirements: ISO 9393</p> <p>Installation criteria: DVS 2204, DVS 2221, UNI 11242</p> <p>Actuator couplings: ISO 5211</p>
Valve material	PVC-U
Seal material	EPDM, FKM (standard size O-Ring); PTFE (ball seats)
Control options	Manual control; electric actuator; pneumatic actuator

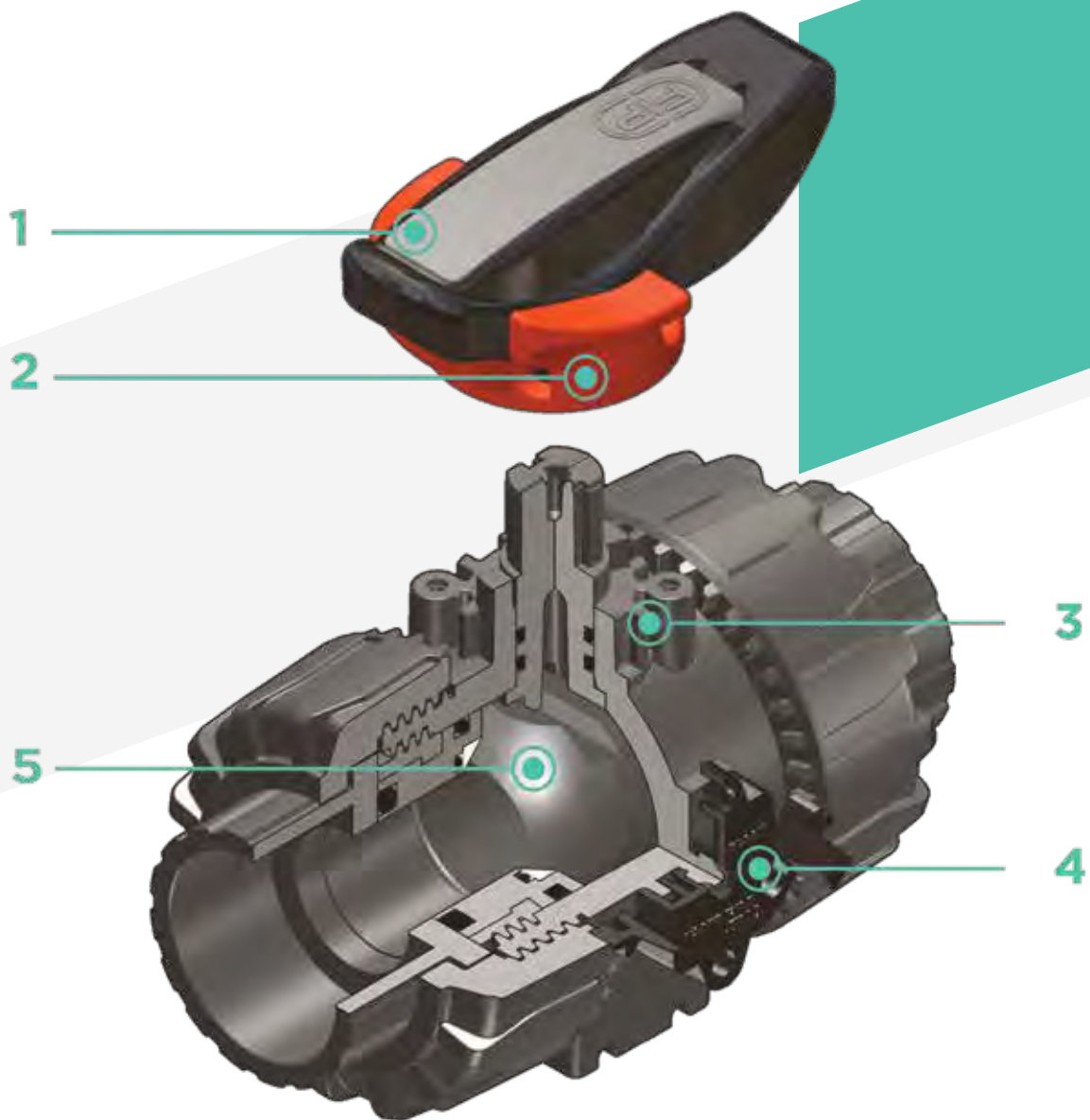

1 Ergonomic HIPVC handle equipped with **removable tool to adjust the ball seat carrier.**

2 **Handle lock 0°- 90° SHKD** (available as an accessory) ergonomically operable during service and padlockable

3 Robust **integrated bracket for valve anchoring**, for easy and quick automation even after valve installation on the system via the Power Quick module (optional)

4 **DUAL BLOCK®** patented lock system that ensures union nut

tightening hold even in severe conditions such as vibrations or heat dilation

5 Machined high surface finish ball that guarantees a smooth operation and increased reliability.

TECHNICAL DATA

PRESSURE VARIATION ACCORDING TO TEMPERATURE

For water and harmless fluids to which the material is classified as CHEMICALLY RESISTANT. In other cases, a reduction of the nominal PN pressure is required (25 years with safety factor).



PRESSURE DROP GRAPH

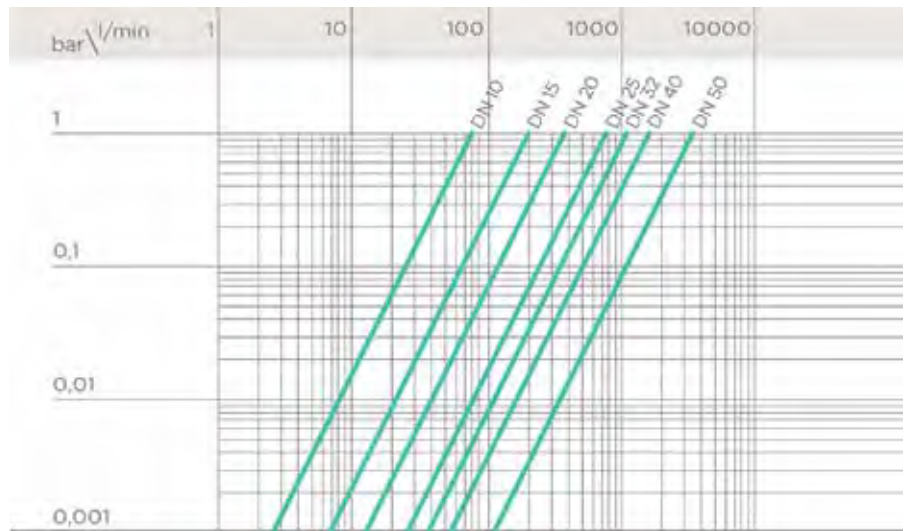

K_v100 FLOW COEFFICIENT

The K_v100 flow coefficient is the Q flow rate of litres per minute of water at a temperature of 20°C that will generate Δp= 1 bar pressure drop at a certain valve position. The K_v100 values shown in the table are calculated with the valve completely open.

DN	10	15	20	25	32	40	50
Kv100 l/min	80	200	385	770	1100	1750	3400

OPERATING TORQUE AT MAXIMUM WORKING PRESSURE

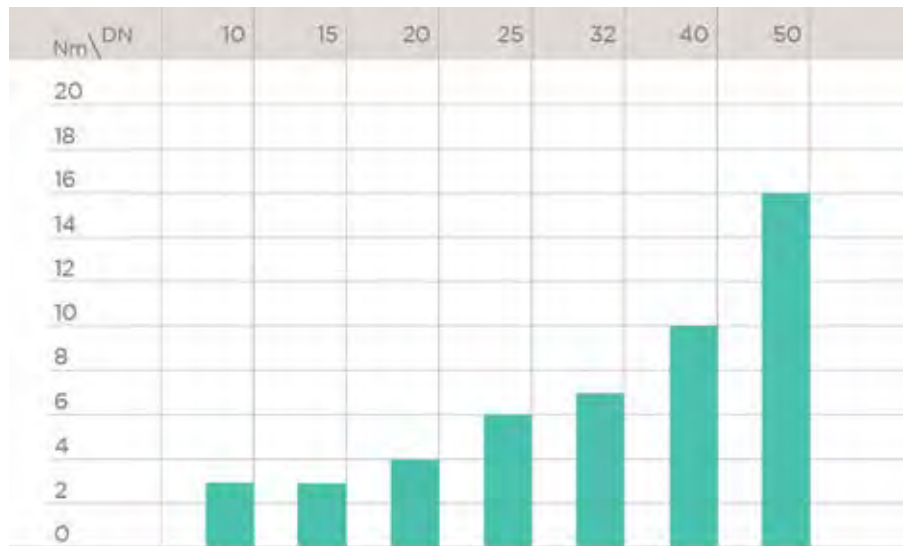

DIMENSIONS

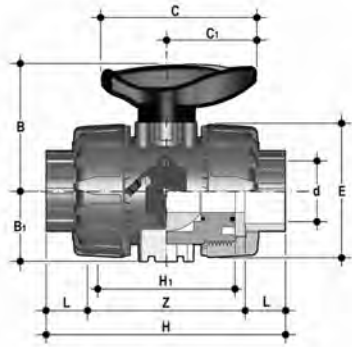

VKDIV

DUAL BLOCK® 2-way ball valve with female ends for solvent welding, metric series

d	DN	PN	B	B ₁	C	C ₁	E	H	H ₁	L	Z	g	EPDM code	FKM code
16	10	16	54	29	67	40	54	103	65	14	75	215	VKDIV016E	VKDIV016F
20	15	16	54	29	67	40	54	103	65	16	71	205	VKDIV020E	VKDIV020F
25	20	16	65	34,5	85	49	65	115	70	19	77	330	VKDIV025E	VKDIV025F
32	25	16	69,5	39	85	49	73	128	78	22	84	438	VKDIV032E	VKDIV032F
40	32	16	82,5	46	108	64	86	146	88	26	94	693	VKDIV040E	VKDIV040F
50	40	16	89	52	108	64	98	164	93	31	102	925	VKDIV050E	VKDIV050F
63	50	16	108	62	134	76	122	199	111	38	123	1577	VKDIV063E	VKDIV063F

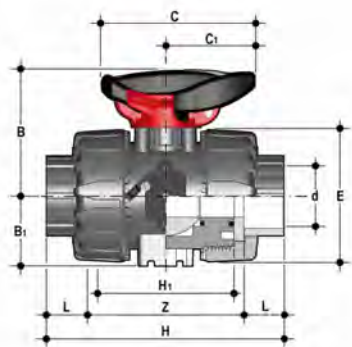

VKDIV/SHX

DUAL BLOCK® 2-way ball valve with handle lock and STAINLESS steel threaded inserts with female ends for solvent welding, metric series

d	DN	PN	B	B ₁	C	C ₁	E	H	H ₁	L	Z	g	EPDM code	FKM code
16	10	16	54	29	67	40	54	103	65	14	75	225	VKDIVSHX016E	VKDIVSHX016F
20	15	16	54	29	67	40	54	103	65	16	71	215	VKDIVSHX020E	VKDIVSHX020F
25	20	16	65	34,5	85	49	65	115	70	19	77	340	VKDIVSHX025E	VKDIVSHX025F
32	25	16	69,5	39	85	49	73	128	78	22	84	448	VKDIVSHX032E	VKDIVSHX032F
40	32	16	82,5	46	108	64	86	146	88	26	94	703	VKDIVSHX040E	VKDIVSHX040F
50	40	16	89	52	108	64	98	164	93	31	102	935	VKDIVSHX050E	VKDIVSHX050F
63	50	16	108	62	134	76	122	199	111	38	123	1587	VKDIVSHX063E	VKDIVSHX063F

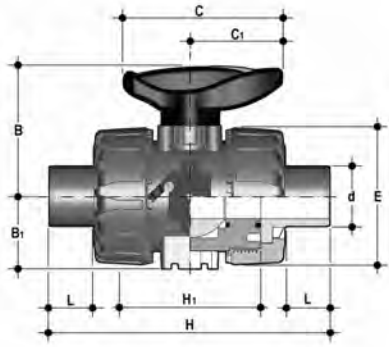

VKDDV

DUAL BLOCK® 2-way ball valve with male ends for solvent welding, metric series

d	DN	PN	B	B ₁	C	C ₁	E	H	H ₁	L	g	EPDM code	FKM code
16	10	16	54	29	67	40	54	149	65	14	215	VKDDV016E	VKDDV016F
20	15	16	54	29	67	40	54	124	65	16	220	VKDDV020E	VKDDV020F
25	20	16	65	34,5	85	49	65	144	70	19	340	VKDDV025E	VKDDV025F
32	25	16	69,5	39	85	49	73	154	78	22	443	VKDDV032E	VKDDV032F
40	32	16	82,5	46	108	64	86	174	88	26	693	VKDDV040E	VKDDV040F
50	40	16	89	52	108	64	98	194	93	31	945	VKDDV050E	VKDDV050F
63	50	16	108	62	134	76	122	224	111	38	1607	VKDDV063E	VKDDV063F

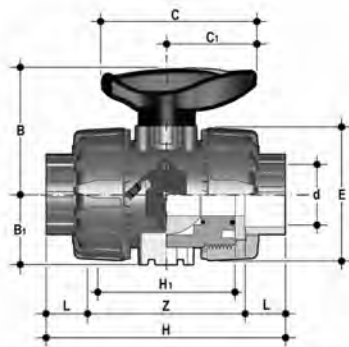

VKDLV

DUAL BLOCK® 2-way ball valve with female ends for solvent welding, BS series

d	DN	PN	B	B ₁	C	C ₁	E	H	H ₁	L	Z	g	EPDM code	FKM code
3/8"	10	16	54	29	67	40	54	103	65	14,5	74	210	VKDLV038E	VKDLV038F
1/2"	15	16	54	29	67	40	54	103	65	16,5	70	205	VKDLV012E	VKDLV012F
3/4"	20	16	65	34,5	85	49	65	115	70	19	77	335	VKDLV034E	VKDLV034F
1"	25	16	69,5	39	85	49	73	128	78	22,5	83	433	VKDLV100E	VKDLV100F
1" 1/4	32	16	82,5	46	108	64	86	146	88	26	94	703	VKDLV114E	VKDLV114F
1" 1/2	40	16	89	52	108	64	98	164	93	30	104	925	VKDLV112E	VKDLV112F
2"	50	16	108	62	134	76	122	199	111	36	127	1647	VKDLV200E	VKDLV200F

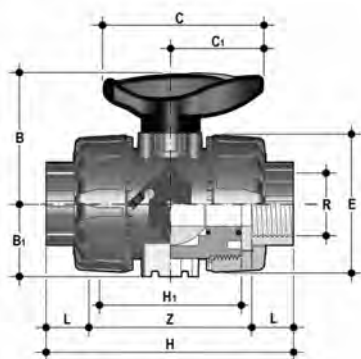

VKDFV

DUAL BLOCK® 2-way ball valve with BSP threaded female ends

R	DN	PN	B	B ₁	C	C ₁	E	H	H ₁	L	Z	g	EPDM code	FKM code
3/8"	10	16	54	29	67	40	54	103	65	12**	80	215	VKDFV038E	VKDFV038F
1/2"	15	16	54	29	67	40	54	110	65	15	80	210	VKDFV012E	VKDFV012F
3/4"	20	16	65	34,5	85	49	65	116	70	16	83	335	VKDFV034E	VKDFV034F
1"	25	16	69,5	39	85	49	73	134	78	19	96	448	VKDFV100E	VKDFV100F
1" 1/4	32	16	82,5	46	108	64	86	153	88	21	110	678	VKDFV114E	VKDFV114F
1" 1/2	40	16	89	52	108	64	98	156	93	21	113	955	VKDFV112E	VKDFV112F
2"	50	16	108	62	134	76	122	186	111	26	135	1667	VKDFV200E	VKDFV200F

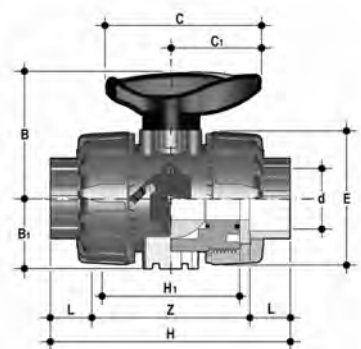

VKDAV

DUAL BLOCK® 2-way ball valve with female ends for solvent* welding, ASTM series

d	DN	PN	B	B ₁	C	C ₁	E	H	H ₁	L	Z	g	EPDM code	FKM code
3/8"	10	16	54	29	67	40	54	117	65	19,5	78	230	VKDAV038E	VKDAV038F
1/2"	15	16	54	29	67	40	54	117	65	22,5	72	215	VKDAV012E	VKDAV012F
3/4"	20	16	65	34,5	85	49	65	129	70	25,5	78	345	VKDAV034E	VKDAV034F
1"	25	16	69,5	39	85	49	73	142	78	28,7	84,6	448	VKDAV100E	VKDAV100F
1" 1/4	32	16	82,5	46	108	64	86	162	88	32	98	718	VKDAV114E	VKDAV114F
1" 1/2	40	16	89	52	108	64	98	172	93	35	102	975	VKDAV112E	VKDAV112F
2"	50	16	108	62	134	76	122	199	111	38,2	122,6	1712	VKDAV200E	VKDAV200F

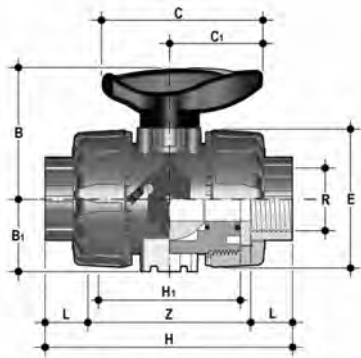

VKDNV

DUAL BLOCK® 2-way ball valve with female ends, NPT thread

R	DN	PN	B	B ₁	C	C ₁	E	H	H ₁	L	Z	g	EPDM code	FKM code
3/8"	10	16	54	29	67	40	54	103	65	13,7	75,6	215	VKDNV038E	VKDNV038F
1/2"	15	16	54	29	67	40	54	111	65	17,8	75,4	210	VKDNV012E	VKDNV012F
3/4"	20	16	65	34,5	85	49	65	117	70	18	81	335	VKDNV034E	VKDNV034F
1"	25	16	69,5	39	85	49	73	135	78	22,6	89,8	448	VKDNV100E	VKDNV100F
1" 1/4	32	16	82,5	46	108	64	86	153	88	25,1	102,8	678	VKDNV114E	VKDNV114F
1" 1/2	40	16	89	52	108	64	98	156	93	24,7	106,6	955	VKDNV112E	VKDNV112F
2"	50	16	108	62	134	76	122	186	111	29,6	126,8	1667	VKDNV200E	VKDNV200F

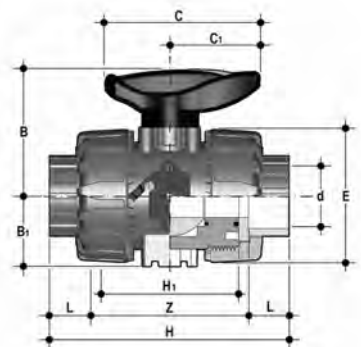

VKDJV

DUAL BLOCK® 2-way ball valve with female ends for solvent welding, JIS series

d	DN	PN	B	B ₁	C	C ₁	E	H	H ₁	L	Z	g	EPDM code	FKM code
1/2"	15	16	54	29	67	40	54	131	65	30	71	225	VKDJV012E	VKDJV012F
3/4"	20	16	65	34,5	85	49	65	147	70	35	77	335	VKDJV034E	VKDJV034F
1"	25	16	69,5	39	85	49	73	164	78	40	84	448	VKDJV100E	VKDJV100F
1" 1/4	32	16	82,5	46	108	64	86	182	88	44	94	728	VKDJV114E	VKDJV114F
1" 1/2	40	16	89	52	108	64	98	212	93	55	102	1015	VKDJV112E	VKDJV112F
2"	50	16	108	62	134	76	122	248	111	63	122	1727	VKDJV200E	VKDJV200F

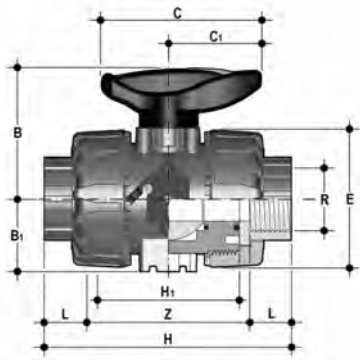

VKDGV

DUAL BLOCK® 2-way ball valve with female ends, JIS thread

R	DN	PN	B	B ₁	C	C ₁	E	H	H ₁	L	Z	g	EPDM code	FKM code
1/2"	15	16	54	29	67	40	54	103	65	16	71	210	VKDGV012E	VKDGV012F
3/4"	20	16	65	34,5	85	49	65	115	70	19	77	330	VKDGV034E	VKDGV034F
1"	25	16	69,5	39	85	49	73	128	78	22	84	438	VKDGV100E	VKDGV100F
1" 1/4	32	16	82,5	46	108	64	86	146	88	25	96	678	VKDGV114E	VKDGV114F
1" 1/2	40	16	89	52	108	64	98	164	93	26	112	975	VKDGV112E	VKDGV112F
2"	50	16	108	62	134	76	122	199	111	31	137	1627	VKDGV200E	VKDGV200F

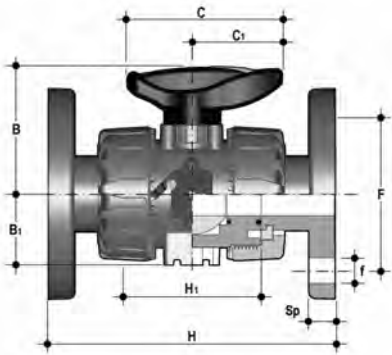

VKDOV

DUAL BLOCK® 2-way ball valve with EN/ISO/DIN PN 10/16 fixed flanges, Face to face according to EN 558-1

d	DN	PN	B	B ₁	C	C ₁	F	f	H	H ₁	Sp	U	g	EPDM code	FKM code
20	15	16	54	29	67	40	65	14	130	65	11	4	375	VKDOV020E	VKDOV020F
25	20	16	65	34,5	85	49	75	14	150	70	14	4	590	VKDOV025E	VKDOV025F
32	25	16	69,5	39	85	49	85	14	160	78	14	4	713	VKDOV032E	VKDOV032F
40	32	16	82,5	46	108	64	100	18	180	88	14	4	1108	VKDOV040E	VKDOV040F
50	40	16	89	52	108	64	110	18	200	93	16	4	1485	VKDOV050E	VKDOV050F
63	50	16	108	62	134	76	125	18	230	111	16	4	2347	VKDOV063E	VKDOV063F

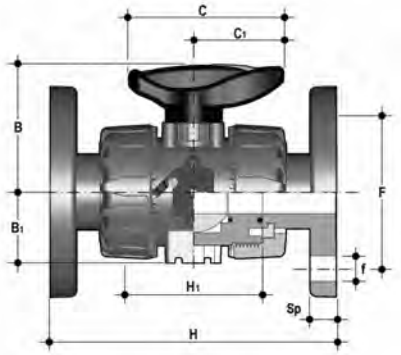

VKDOAV

DUAL BLOCK® 2-way ball valve with fixed flange, drilled ANSI B16.5 cl.150#FF

d	DN	PN	B	B ₁	C	C ₁	F	f	H	H ₁	Sp	U	g	EPDM code	FKM code
1/2"	15	16	54	29	67	40	60,3	15,9	143	65	11	4	460	VKDOAV012E	VKDOAV012F
3/4"	20	16	65	34,5	85	49	69,9	15,9	172	70	14	4	632	VKDOAV034E	VKDOAV034F
1"	25	16	69,5	39	85	49	79,4	15,9	187	78	14	4	853	VKDOAV100E	VKDOAV100F
1" 1/4	32	16	82,5	46	108	64	88,9	15,9	190	88	14	4	1313	VKDOAV114E	VKDOAV114F
1" 1/2	40	16	89	52	108	64	98,4	15,9	212	93	16	4	1669	VKDOAV112E	VKDOAV112F
2"	50	16	108	62	134	76	120,7	19,1	234	111	16	4	2577	VKDOAV200E	VKDOAV200F

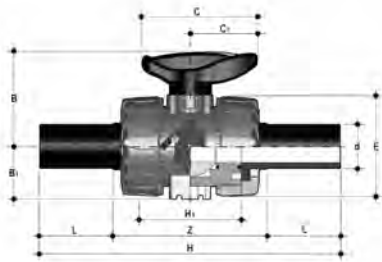

VKDBEV

DUAL BLOCK® 2-way ball valve with PE100 SDR 11 male end connectors for butt welding or electrofusion (CVDE)

d	DN	PN	B	B ₁	C	C ₁	E	H	H ₁	L	Z	g	EPDM code	FKM code
20	15	16	54	29	67	40	54	175	65	40,5	94	220	VKDBEV020E	VKDBEV020F
25	20	16	65	34,5	85	49	65	213	70	54	106	340	VKDBEV025E	VKDBEV025F
32	25	16	69,5	39	85	49	73	228	78	56	117	443	VKDBEV032E	VKDBEV032F
40	32	16	82,5	46	108	64	86	247	88	56	131	693	VKDBEV040E	VKDBEV040F
50	40	16	89	52	108	64	98	271	93	60,5	145	945	VKDBEV050E	VKDBEV050F
63	50	16	108	62	134	76	122	300	111	65,5	161	1607	VKDBEV063E	VKDBEV063F

ACCESSORIES

CVDE

Long spigot PE100 end connectors for joints with electrofusion fittings or for butt welding

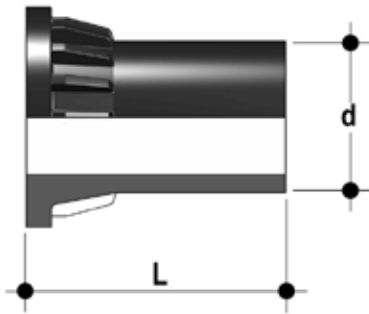

d	DN	PN	L	SDR	Code
20	15	16	55	11	CVDE11020
25	20	16	70	11	CVDE11025
32	25	16	74	11	CVDE11032
40	32	16	78	11	CVDE11040
50	40	16	84	11	CVDE11050
63	50	16	91	11	CVDE11063

SHKD

Handle block kit 0° - 90° lockable



d	DN	Code
16 - 20	10 - 15	SHKD020
25 - 32	20 - 25	SHKD032
40 - 50	32 - 40	SHKD050
63	50	SHKD063

PMKD

Wall mounting plate

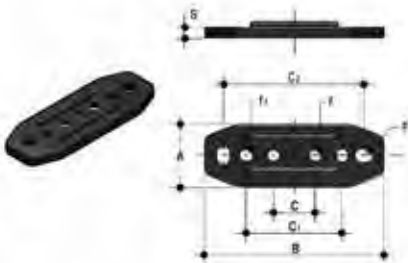

d	DN	A	B	C	C ₁	C ₂	F	f	f ₁	S	Code
16	10	30	86	20	46	67,5	6,5	5,3	5,5	5	PMKD1
20	15	30	86	20	46	67,5	6,5	5,3	5,5	5	PMKD1
25	20	30	86	20	46	67,5	6,5	5,3	5,5	5	PMKD1
32	25	30	86	20	46	67,5	6,5	5,3	5,5	5	PMKD1
40	32	40	122	30	72	102	6,5	6,3	6,5	6	PMKD2
50	40	40	122	30	72	102	6,5	6,3	6,5	6	PMKD2
63	50	40	122	30	72	102	6,5	6,3	6,5	6	PMKD2

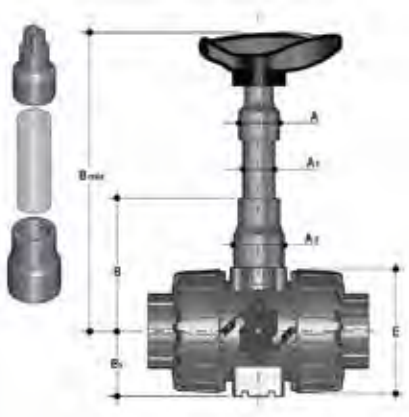

PSKD

Stem extension

d	DN	A	A ₁	A ₂	E	B	B ₁	B _{min}	Code
16	10	32	25	32	54	70	29	139,5	PSKD020
20	15	32	25	32	54	70	29	139,5	PSKD020
25	20	32	25	40	65	89	34,5	164,5	PSKD025
32	25	32	25	40	73	93,5	39	169	PSKD032
40	32	40	32	50	86	110	46	200	PSKD040
50	40	40	32	50	98	116	52	206	PSKD050
63	50	40	32	59	122	122	62	225	PSKD063



Easytorque Kit

Kit for ball seat carrier tightening adjustment for DUAL BLOCK® DN 10÷50 series valves

d	DN	Tightening torque recommended*	Code
3/8"-1/2"	10-15	3 N m - 2,21 Lbf ft	KET01
3/4"	20	4 N m - 2,95 Lbf ft	KET01
1"	25	5 N m - 3,69 Lbf ft	KET01
1" 1/4	32	5 N m - 3,69 Lbf ft	KET01
1" 1/2	40	7 N m - 5,16 Lbf ft	KET01
2"	50	9 N m - 6,64 Lbf ft	KET01

*calculated in ideal installation conditions

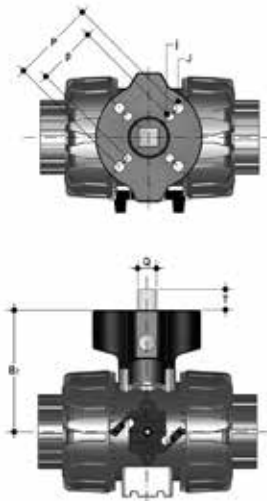

Power Quick/CP

The valve can be equipped with pneumatic actuators, using the PP-GR module reproducing the drilling pattern foreseen by ISO 5211

d	DN	B ₂	Q	T	p x j	P x J	Code
16	10	58	11	12	F03 x 5,5	F04 x 5,5	PQCP020
20	15	58	11	12	F03 x 5,5	F04 x 5,5	PQCP020
25	20	69	11	12	*F03 x 5,5	F05 x 6,5	PQCP025
32	25	74	11	12	*F03 x 5,5	F05 x 6,5	PQCP032
40	32	91	14	16	F05 x 6,5	F07 x 8,5	PQCP040
50	40	97	14	16	F05 x 6,5	F07 x 8,5	PQCP050
63	50	114	14	16	F05 x 6,5	F07 x 8,5	PQCP063

*F04 x 5.5 on request

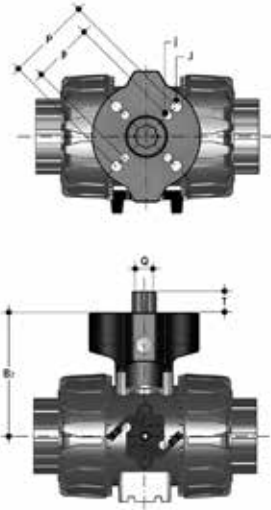

Power Quick/CE

The valve can be equipped with electric actuators, using the PP-GR module reproducing the drilling pattern foreseen by ISO 5211

d	DN	B ₂	Q	T	p x j	P x J	Code
16	10	58	14	16	F03 x 5,5	F04 x 5,5	PQCE020
20	15	58	14	16	F03 x 5,5	F04 x 5,5	PQCE020
25	20	69	14	16	*F03 x 5,5	F05 x 6,5	PQCE025
32	25	74	14	16	*F03 x 5,5	F05 x 6,5	PQCE032
40	32	91	14	16	F05 x 6,5	F07 x 8,5	PQCE040
50	40	97	14	16	F05 x 6,5	F07 x 8,5	PQCE050
63	50	114	14	16	F05 x 6,5	F07 x 8,5	PQCE063

*F04 x 5.5 on request

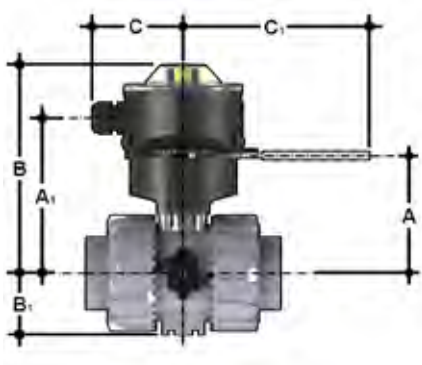

LS Quick Kit

The Limit Switch Quick Kit allows the fast and secure installation of the FIP LSQT to the VKD valves. The body is in PP-GR and the handle is in stainless steel AISI 316. The handle block at 0° and 90° is also available by default (hole diameter 6.5 mm). The kit can be assembled on the valve even if already installed on the system. For technical data of the LSQT box see FIP actuated valves catalogue.

d	DN	A	A ₁	B	B ₁	C	C ₁	Code
16	10	60	91,5	137	29	76,5	157,5	LSQKIT20
20	15	60	91,5	137	29	76,5	157,5	LSQKIT20
25	20	71	102,5	148	34,5	76,5	157,5	LSQKIT25
32	25	76	107,5	153	39	76,5	157,5	LSQKIT32
40	32	93	124,5	170	46	76,5	157,5	LSQKIT40
50	40	99	130,5	176	52	76,5	157,5	LSQKIT50
63	50	116	147,5	193	62	76,5	157,5	LSQKIT63

FASTENING AND SUPPORTING



All valves, whether manual or actuated, must be adequately supported in many applications. The VKD valve series is therefore provided with an integrated bracket that permits direct anchoring of the valve body without the need of other components. For wall installation, dedicated PMKD mounting plates which are available as accessories can be used. These plates should be fastened to the valve before wall installation. PMKD plates also allow VKD valve alignment with FIP ZIKM pipe clips as well as allowing different sizes of valves to be aligned.

d	DN	g	H	L	J*
16	10	31,5	27	20	M4 x 6
20	15	31,5	27	20	M4 x 6
25	20	40	30	20	M4 x 6
32	25	40	30	20	M4 x 6
40	32	50	35	30	M6 x 10
50	40	50	35	30	M6 x 10
63	50	60	40	30	M6 x 10

* With threaded inserts

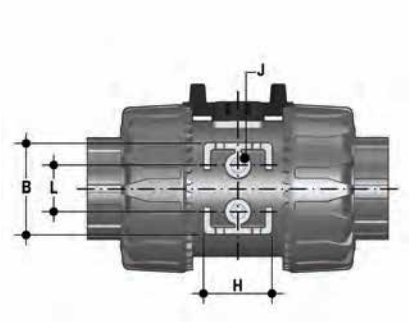

COMPONENTS

EXPLODED VIEW

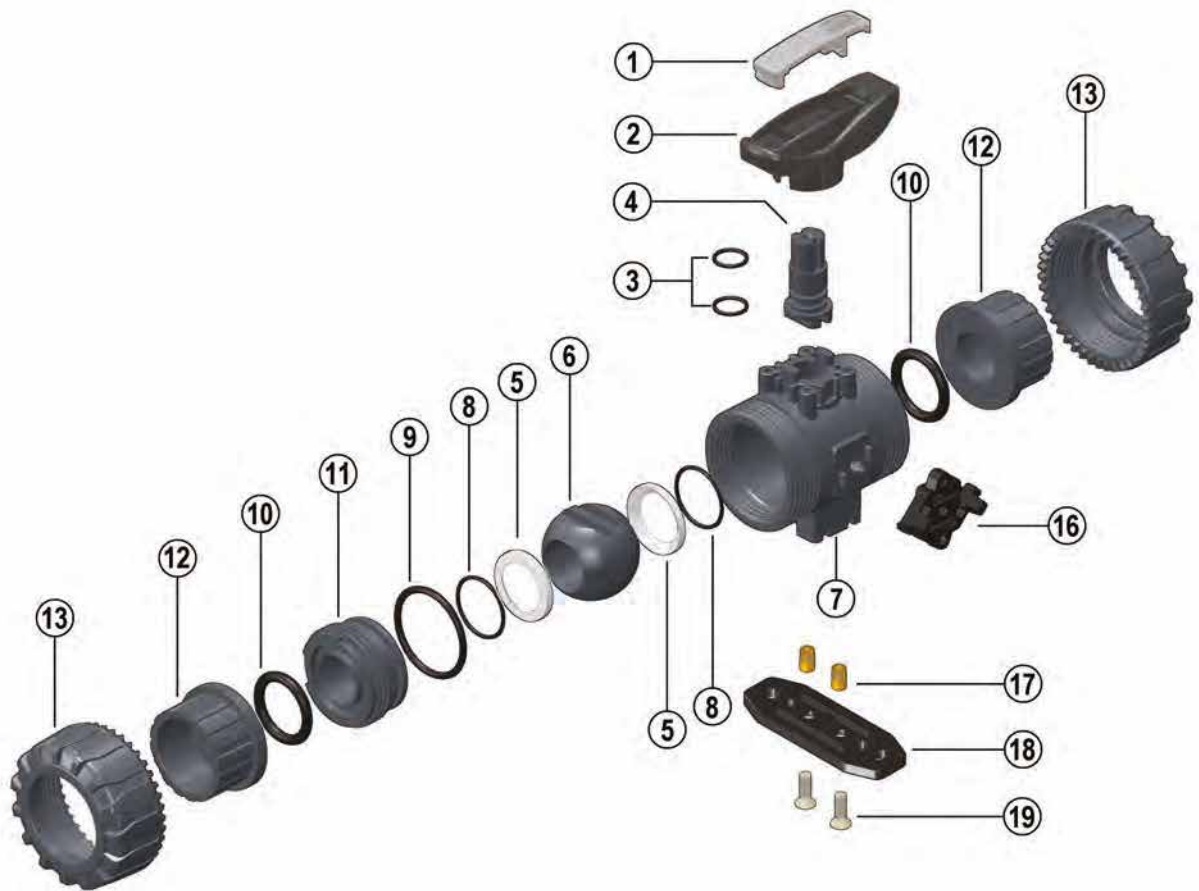

- | | | |
|--|--|---|
| 1 Handle insert (PVC-U - 1) | 9 Radial seal O-Ring (EPDM-FKM - 1)* | 15 Handle safety block (PP-GR - 1)** |
| 2 Handle (HIPVC - 1) | 10 Socket seal O-Ring (EPDM-FKM - 2)* | 16 DUAL BLOCK® (POM - 1) |
| 3 Stem O-rings (EPDM-FKM - 2)* | 11 Ball seat carrier (PVC-U - 1) | 17 Threaded inserts (STAINLESS steel or Brass - 2)** |
| 4 Stem (PVC-U - 1) | 12 End connector (PVC-U - 2)* | 18 Distance plate (PP-GR - 1)** |
| 5 Ball seat (PTFE - 2)* | 13 Union nut (PVC-U - 2) | 19 Screw (STAINLESS steel - 2)** |
| 6 Ball (PVC-U - 1) | 14 Spring (STAINLESS steel - 1)** | |
| 7 Body (PVC-U - 1) | | |
| 8 Ball seat O-Rings (EPDM-FKM - 2)* | | |

* Spare parts

** Accessories

The component material and quantity supplied are indicated in the parentheses.

DISASSEMBLY

- 1) Isolate the valve from the line (release the pressure and empty the pipeline).
- 2) Unlock the union nuts by pressing the lever on the DUAL BLOCK® (16) along the axis and separate it from the union nut (fig. 1-2). It is also possible to completely remove the block device from the body of the valve.
- 3) Fully unscrew the union nuts (13) and extract the body sideways.
- 4) Before dismounting, hold the valve in a vertical position and open it 45° to drain any liquid that might remain.
- 5) After closing the valve, remove the special insert (1) from the handle (2) and push the two projecting ends into the corresponding recesses on the ball seat carrier (11). Rotate the stop ring anti-clockwise to extract it (fig. 3-4).
- 6) Pull the handle (2) upwards to remove it from the valve stem (4).
- 7) Press on the ball from the side opposite the "REGULAR - ADJUST" label, being sure not to scratch it, until the ball seat carrier exits (11), then extract the ball (6).
- 8) Press the stem (4) inwards until it exits the body.
- 9) Remove the O-Ring (3, 8, 9, 10) and PTFE ball seats (5) extracting them from their grooves, as illustrated in the exploded view.

ASSEMBLY

- 1) All the O-rings (3, 8, 9, 10) must be inserted in their grooves as shown in the exploded view.
- 2) Insert the stem (4) from inside the valve body (7).
- 3) Place the PTFE ball seats (5) in the housings in the body (7) and in the ball seat ball seat carrier (11).
- 4) Insert the ball (6) rotating it to the closed position.
- 5) Screw the carrier (11) into the body and tighten up in the clockwise direction using the handle (2) to limit stop.
- 6) Insert the valve between the end connectors (12) and tighten the union nuts (13) making sure that the socket seal O-rings (10) do not exit their seats.
- 7) The handle (2) should be placed on the valve stem (4).



Note: during assembly operations, it is advisable to lubricate the rubber seals. Mineral oils are not recommended for this task as they react aggressively with EPDM rubber.

Fig. 1



Fig. 2



Fig. 3



Fig. 4



INSTALLATION

Before proceeding with installation, please follow these instructions carefully:

- 1) Check that the pipes to be connected to the valve are aligned in order to avoid mechanical stress on the threaded joints.
- 2) Check that the DUAL BLOCK® union nut locking device (16) is fitted to the valve body.
- 3) To release the union nuts, axially press the release lever to separate the lock and then unscrew it in the counter-clockwise direction.
- 4) Unscrew the union nuts (13) and insert them on the pipe segments.
- 5) Solvent weld or screw the end connectors (12) onto the pipe ends.
- 6) Position the valve body between the end connectors and fully tighten the union nuts (13) manually by rotating clockwise without using wrenches or other tools that could damage the union nut surface.
- 7) Lock the union nuts by returning the DUAL BLOCK® to its housing, pressing on it until the hinges lock on the union nuts.
- 8) If necessary, support the pipework with FIP pipe clips or by means of the carrier built into the valve itself (see paragraph "fastening and carriers").

The VKD valve can be equipped with a handle lock to prevent ball rotation (supplied separately).

When the handle safety block (14, 15) is installed, lift the lever (15) and rotate the handle (fig. 6-7).

A lock can also be installed on the handle to protect the system against tampering (fig. 8).

Seal can be adjusted using the extractable insert on the handle (fig. 3-4). The seals can be adjusted later with the valve installed on the pipe by simply tightening the union nuts. This "micro adjustment", only possible with FIP valves thanks to the patented "Seat stop system", allows the seal to be recovered where PTFE ball seats are worn due to a high number of operations. The Easytorque kit can also be used for micro adjustments (fig. 5).

WARNINGS

- If volatile liquid such as Hydrogen Peroxide (H₂O₂) or Sodium Hypochlorite (NaClO) are used, for safety reasons we recommend you contact the service centre. These liquids, upon vaporising, could create hazardous over pressures in the area between the body and ball.
- Always avoid sudden closing operations and protect the valve from accidental operations.

Fig. 5



Fig. 6



Fig. 7



Fig. 8





technische import