



technische import

Produkt informatie



HANS SASSERATH & Co. KG

Thermostatic mixing valve 702 Safe

with protection against scalding



Field of application

The thermostatic mixing valve type 702 Safe is used for the central and local regulation of the water temperature in potable water supply installations. It is the optimal solution for kindergarten, retirement homes, swimming pools, public buildings etc. Corrosion and sediments are reduced as it is installed directly at the hot water outlet of

potable water heaters that operate at high temperatures for capacity or system inherent reasons. In addition, the operation with a reduced draw-off temperature is more economic. The thermostatic mixing valve type 702 Safe can also limit the return temperature in heating installations or underfloor heating systems.

Design

This device works as a proportionally operating thermostatic mixing valve with a thermoelement. The body (nickel-plated) supplied with threaded unions on all sides (soldered unions available on request) is removable along with the thermostatic element. The integral scalding protection (in compliance with European Standards) automatically stops the incoming hot water when the cold water supply is interrupted.

The check valves installed in both cold and hot water inlets prevent any incorrect circulation. The integral strainers protect the function parts against impurities originating from the supply network. When the mixing valve is installed in a system with a circulation pump, it is recommended to have a time or temperature controlled pump.



Thermostatic mixing valve 702 Safe

Materials	The body and internal parts are made of a high quality low-lead brass alloy and glass fibre reinforced synthetic material; the adjustment knob is also made of high quality	synthetic material. The spring is made of corrosion resistant spring steel wire and the sealing elements of heat resistant elastomeric synthetic material.																		
Installation	Install the mixing valve in any mounting position. Follow the connection instructions Thoroughly flush the pipes prior to installation. It is recommended to install a filter at the domestic point of entry to ensure a durable and correct operation.	in the user's manual. Install the device in the pipe without applying stresses. The cold water inlet is marked with „C“ and the hot water inlet with „H“.																		
Technical data	<table><tr><td>Operating pressure:</td><td>max. 10 bar</td></tr><tr><td>Inlet temperature, hot water:</td><td>52 - 95 °C</td></tr><tr><td>Inlet temperature, cold water:</td><td>5 - 25 °C</td></tr><tr><td>Temperature setting range:</td><td>35 - 65°C</td></tr><tr><td>Factory-set temperature:</td><td>43 °C</td></tr><tr><td>Flow rate:</td><td>DN 15: 0,35 m³/h at 2m/s, min. 13l/min DN 20: 0,63 m³/h at 2m/s, min.23 l/min</td></tr><tr><td>Mounting position:</td><td>any</td></tr><tr><td>Fluid:</td><td>water</td></tr><tr><td>Serial number:</td><td>0702...</td></tr></table>		Operating pressure:	max. 10 bar	Inlet temperature, hot water:	52 - 95 °C	Inlet temperature, cold water:	5 - 25 °C	Temperature setting range:	35 - 65°C	Factory-set temperature:	43 °C	Flow rate:	DN 15: 0,35 m ³ /h at 2m/s, min. 13l/min DN 20: 0,63 m ³ /h at 2m/s, min.23 l/min	Mounting position:	any	Fluid:	water	Serial number:	0702...
Operating pressure:	max. 10 bar																			
Inlet temperature, hot water:	52 - 95 °C																			
Inlet temperature, cold water:	5 - 25 °C																			
Temperature setting range:	35 - 65°C																			
Factory-set temperature:	43 °C																			
Flow rate:	DN 15: 0,35 m ³ /h at 2m/s, min. 13l/min DN 20: 0,63 m ³ /h at 2m/s, min.23 l/min																			
Mounting position:	any																			
Fluid:	water																			
Serial number:	0702...																			
Maintenance	Remove the blue cap to adjust the desired temperature. The key included in the delivery allows to easily regulate the temperature with open draw-off valve and both hot and cold water inlets fully turned	on. Turn anti-clockwise to increase the temperature and clockwise to decrease it. No particular maintenance is required under normal operating circumstances.																		

Thermostatical mixing valve 702 Safe

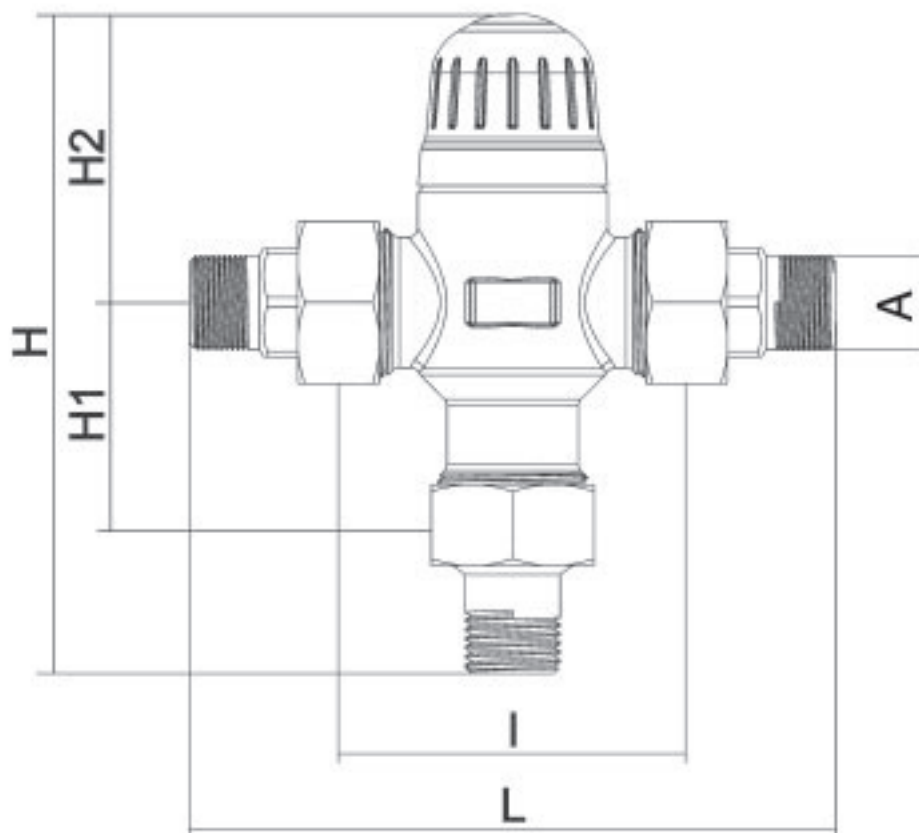

Nominal size		DN 15	DN 20
	A	G 1/2	G 3/4
	(mm)	15	22
Dimensions	H (mm)	147	148
	H 1 (mm)	50	50
	H 2 (mm)	64	64
	L (mm)	143	146
	l (mm)	78	78

Thermostatical mixing valve 702 Safe

Components / Order numbers

- ①
Cap
- ②
Thermoelement, spring and control piston
0702.00.902
- ③
Check valve
DN 15: 0702.15.901
DN 20: 0702.20.901
- ④
Strainer
0702.00.901
- ⑤
Sealing kit (3 units)
0702.00.900

