



technische import

Produkt informatie

COSTER

COSTER T.E.

REVERSIBLE ROTARY ACTUATOR FOR HGT - HGM - HMM - VDM VALVES

CDR 064 Eng.

- Power supply : 24 V ~
- Three-wire electric control (common, opens, closes)
- Rotation angle : 90°
- Run time: 60 seconds
- Direct mounting on valve
- Specially indicated for installation in dwellings
- IP 54 protection



1. APPLICATION

CDR 064 actuator is of the rotary type, suitable for operating HGT radiator ball valves, HGM – HMM ball zone valves and VDM ceramic disk control valves. On all these types of valves the actuator can be attached directly, so no mounting kit is necessary.

The voltage required (24 ~), the colour of the cover and the white output cable for the electrical connections make CDR 064 particularly suitable for use with valves that are sited inside dwellings and offices.

2. OPERATION

CDR 064 actuator is equipped with a small, synchronous, reversible electric motor requiring three-wire control (common, opens, closes).

It can be controlled by an O-Off device (thermostat, remote switch, manual switch) with SPDT output, or by a modulating controller.

The electric motor transmits its rotary movement to a speed reducer which determines the rotation speed of the output shaft and, accordingly, the actuator run time. The rotation angle of the actuator is 90° and is limited by two microswitches operated by an end-of-run cam.

3. TECHNICAL DATA

Power supply	24 V~ ± 10%
Frequency	50...60 Hz
Consumption	4 VA
Rotation angle	fixed at 90°
Run time	60 seconds
Suitable valves	HGT-HGM-HMM-VDM
Nominal torque	15 kg/cm (1.5 Nm)
Starting torque	30 kg/cm (3.0 Nm)
Materials:	
– base	Nylon + glass fibre
– cover	ABS
Valve fluid temperature	5...95 °C
Ambient temperature :	
– operating	0...45 °C
– storage	- 20...60 °C
Protection	IP 54
Weight	0.280 kg

4. OVERALL DIMENSIONS

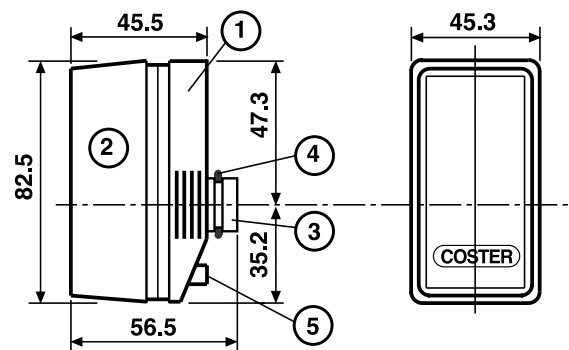

- | | |
|----------------------------|---------------------|
| 1 – Base | 4 – Securing spring |
| 2 – Protective cover | 5 – 1.5 metre cable |
| 3 – Valve coupling element | |

5. CONSTRUCTION

The base of the actuator (4.1) is made of Nylon reinforced with glass fibre, while the cover (4.2) is in ABS. The protection rating is IP 54.

Electrical connection is by means of a white, pre-wired 1.5 metre cable passing through an entry gland (4.5) at the rear of the base. The coupling element at the rear of the base (4.3) permits rapid mounting on the valve.

6. INSTALLING THE ACTUATOR & ELECTRICAL CONNECTIONS

– Ensure that the valve has been correctly mounted: the actuator can be installed in any position except that with the cable entry gland facing upwards. This is to avoid water from condensation or drops from above infiltrating the actuator.

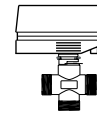

YES

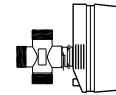

YES

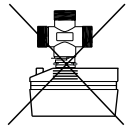

NO

- Installation on **HGT** valves : manually set the valve in the open position and withdraw the handle. Position the actuator (factory setting: open) so that the two recesses in its base coincide with the two spigots on the valve and then press firmly on the actuator until you feel it click into place on the valve.
- Installation on **HGM - HMM - VDM** valves : manually set the valve in the closed position, withdraw the handle and with a suitable tool set the valve to the open position. Position the actuator (factory setting: open) so that the two recesses in its base coincide with the two spigots on the valve and then press firmly on the actuator until you feel it click into place on the valve.
- Carry out the electric wiring in strict accordance with the wiring diagram (section 7) and with the safety regulations in force.
- Power the actuator and make a couple of complete runs to ensure it is working correctly.

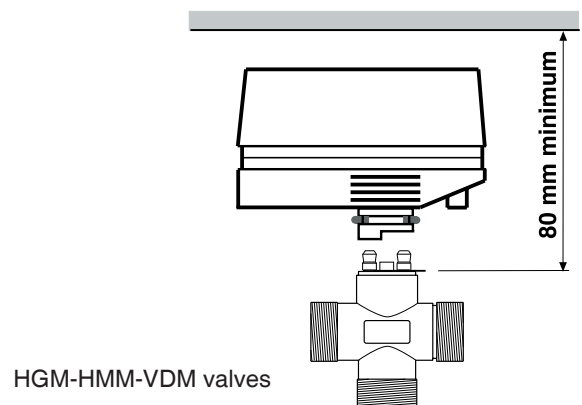
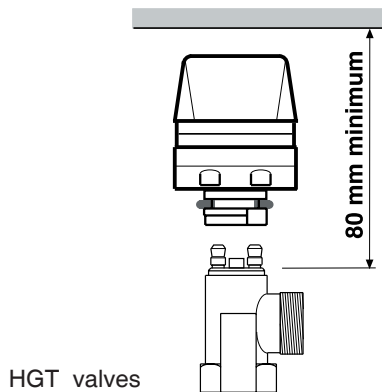

7. WIRING DIAGRAM

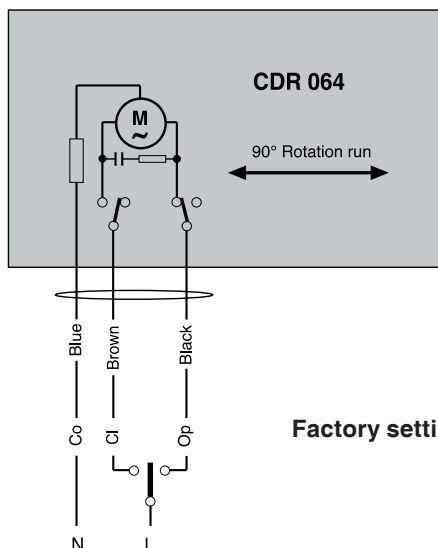

Factory setting : actuator opening

Amendment to data sheet

Date	Revision No.	Page	Section	Amendment description	Firmware version	Software version
08.02.12 AM	01	1	3. TECHNICAL DATA	Changed "Consumption" data		