



technische import

Produkt informatie

COSTER

COSTER T.E.

TWO-PORT VALVES WITH CERAMIC DISK PN 10 ; 1...95°C



VDM 2.. Eng.

- Brass body, spindle in stainless steel
- Ceramic disk rotor
- Male threaded connections complete with unions
- Viton seals



1. APPLICATION

VDM2 valves are designed to control water flow in heating and cooling systems. They are particularly suitable for zone plants, fan-coil plants and for mounting on modular manifolds.

They can be operated by hand or by rotary actuators model CDK and CDR.

Permitted fluids :

- hot water max. 95 °C,
- chilled water min. 1 °C,
- water with max. 50 % glycol.

2. MODELS

Code	Valve connections inches	Pipe connections inches	Kvs ⁽¹⁾ m ³ /h	Suitable actuators CDK ... - CDR ...		
VDM 210	male 1/2"	male 3/8"	1.6	kPa ⁽²⁾	(bar)	sec. ⁽³⁾
VDM 215	male 3/4"	male 1/2"	1.8	600	(6)	60
				600	(6)	60

(1) Kvs = flow coefficient : flow in m³/h with valve open and pressure drop of 100 kPa.

(2) kPa = maximum differential pressure Δp max. permitted by actuator: 100 kPa = 10 mWG = 1 bar

(3) sec. = time necessary for actuator to make complete valve run.

3. OPERATING DIAGRAM

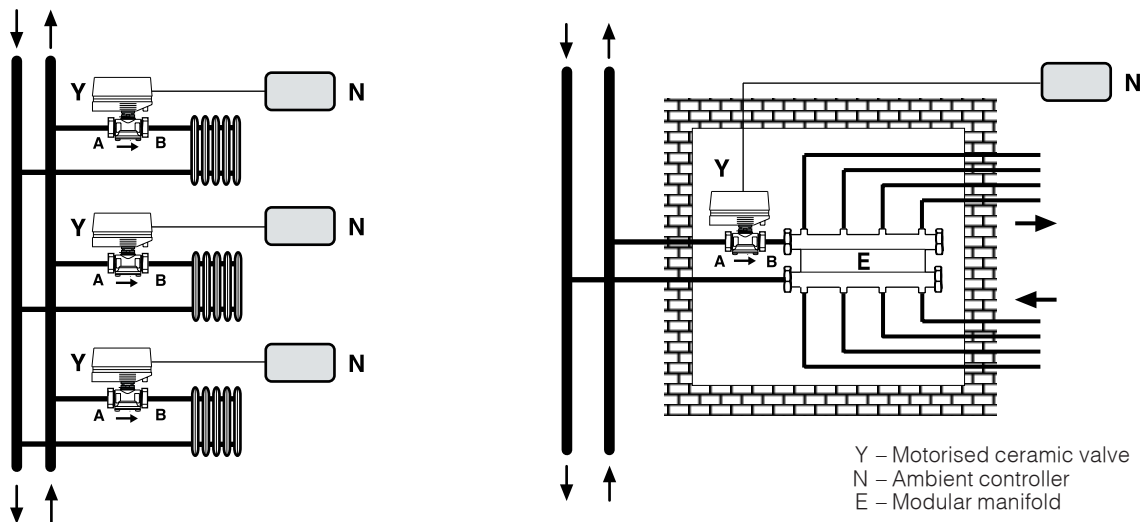

4. TECHNICAL DATA

Valve body	OT58 brass	Connections	male threaded complete with unions
Spindle	stainless steel	Nominal pressure	1,000 kPa (10 bar)
Internal rotor	ceramic disk	Fluid temperature	1...95 °C
Seals	viton O-Ring	Run	90°

5. CONSTRUCTION

The body of the valve (6.8) is made of OT58 brass, the spindle (6.1) and the actuator attachment lugs (6.10) are in stainless steel and the internal rotor (6.3) is a ceramic disk. The spindle and closure plate (6.4) are rendered waterlight by O-Rings inserted in the apposite housings (6.7 e 6.5).

At the head of the valve there is a knob which allows the manual movement.

6. OVERALL DIMENSIONS

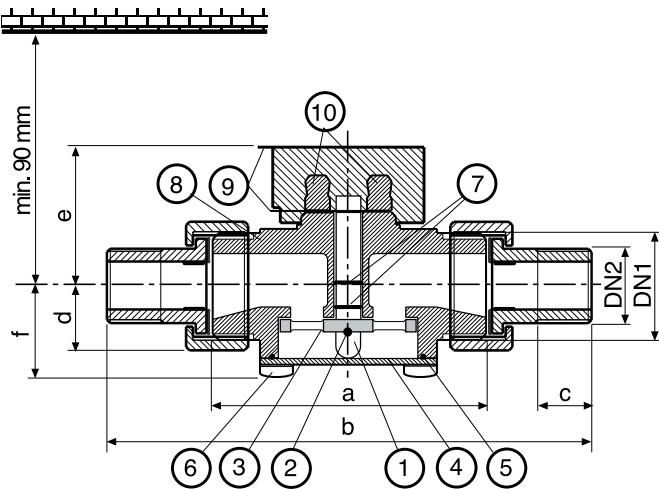

- 1 – Spindle
- 2 – Rotor blocking pin
- 3 – Rotor
- 4 – Closure plug
- 5 – O-Ring plug seal
- 6 – Plug closure screws
- 7 – O-Ring spindle seals
- 8 – Valve body
- 9 – Pointer
- 10 – Actuator attachment lugs

Model	DN 1 inches	DN 2 inches	a mm	b mm	c mm	d mm	e mm	f mm
VDM 210	1/2"	3/8"	43	66	9	14	31.5	24.5
VDM 215	3/4"	1/2"	43	66	10	16.5	31.5	24.5

7. PRESSURE DROP

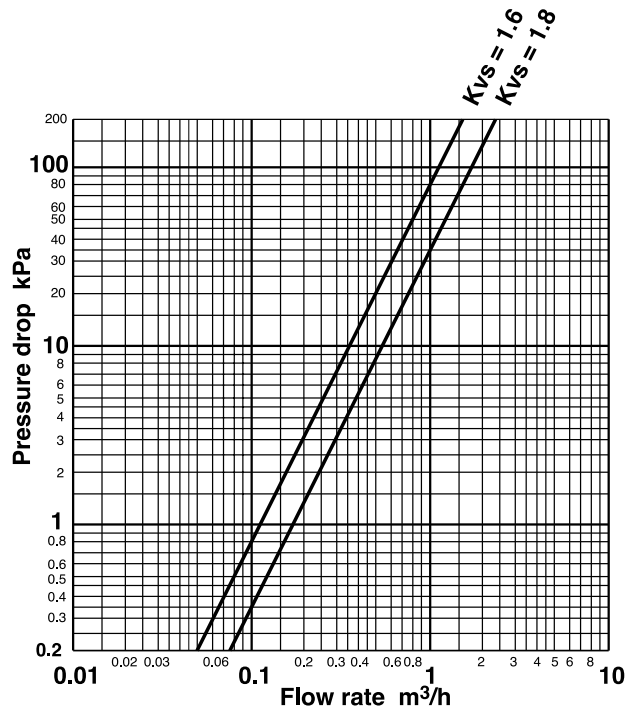

8. MOUNTING

8.1 Mounting of the valve

Before mounting the valve make sure that there isn't any extraneous matter in the pipework (remains of welding or threading). The pipework must not be subject to vibrations and must be perfectly aligned with the valve unions in order to avoid dangerous strains.

Important: to ensure the absence of let-by when closed, it is essential for the valve to be installed according to the flow direction of the fluid. Installation must be carried out so that the letters A and B, embossed on the valve body, appear as shown in the adjoining diagram.

The valve can be mounted in any position except with the spindle facing downwards.

Leave enough space on the spindle side for the mounting of actuator (see section 6).

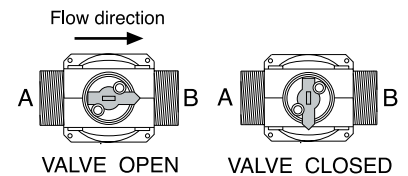
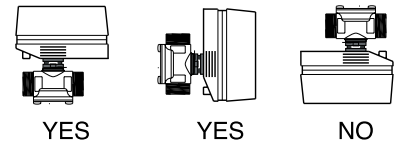

8.2 Installing the actuator on the valve

CDK actuator: by hand, set the valve in the closed position. Pull out the hand grip and then insert and push down the CDK actuator (factory setting: "Closed").

CDR actuator: by hand, set the valve in closed position. Pull out the hand grip and then, using a suitable tool, set the valve in the open position. Then insert and push down the CDR actuator (factory setting: "Open").

9. OPERATION

The valve operates with a 90° rotary movement.

The valve rotor is an appropriately-shaped ceramic disk which, when the valve closes (and provided the valve has been correctly installed in respect of the flow direction A → B), ensure nil let-by.

The valve can be operated by hand, using the hand grip, or by the CDK and CDR actuators.

A mark on the valve spindle, also visible when the actuator is installed, indicates the position of the valve.